

0661 MODEL 467

IBM OEM STORAGE PRODUCTS

FEATURES

- 406MB formatted capacity (520 bytes/sector)
- 400MB formatted capacity (512 bytes/sector)
- Industry-standard interface: ANSI/SCSI-2
- Thermal Compensation
- Integrated controller
- Logical block addressing
- Implied seeks
- SCSI disconnect and reconnect capability
- SCSI bus parity
- Closed-loop actuator servo (dedicated disk servo surface plus data reference)
- Automatic actuator lock
- Dedicated head landing zone
- Average access time: 11.5 mS
- 1:1 interleave
- 1,7 run-length limited (RLL) encoding
- Media data transfer rate: 2MB/S
- SCSI data transfer rate: up to 5MB/S (synchronous)
- 128K dual-ported data buffer
- Buffer memory parity
- Self-diagnostic on power up
- Automatic retry and data correction on read errors
- In-Line alternate sector assignment
- Reassignment of new defective sectors without the need to reformat
- Probability of not recovering data: 1 in to the power of 12 bits read
- Horizontal, back end down, left side, or right side orientation

PERFORMANCE

Data Transfer rate	
Buffer to/from media	2MB/S (instantaneous)
Host to buffer	up to 5MB/S (synchronous)
Host from buffer	up to 5MB/S (synchronous)
Rotational speed	4316 RPM
Average latency	6.95 mS
Sector time	289.5 microS
Seek Time	

Single cylinder	1.0 mS (read) 3.0 mS (write)
Typical	11.0 mS (read) 13.0 mS (write)
Average (weighted)	11.5 mS (4 reads / 1 write)
Full stroke	20.0 mS

ELECTRICAL CONNECTOR LOCATIONS

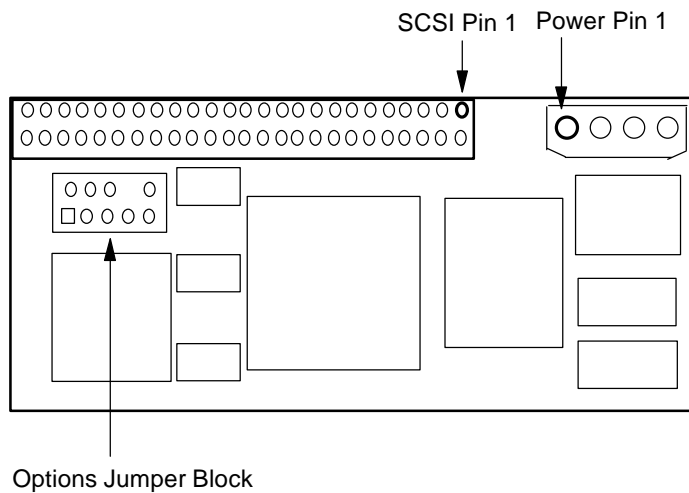

Electrical connectors (view from back of Disk Drive)

Jumper Settings

The jumper block shown above is used to select the SCSI device ID, to control the spindle motor start and to select the appropriate option pin function. There are four ground pins, A1, A2, A3, B2. If pin B1 is jumpered to ground, drive initiated synchronous negotiation is disabled, but requests from the initiator will still be accepted. Option block ground pins must only be used for selecting jumper block functions.

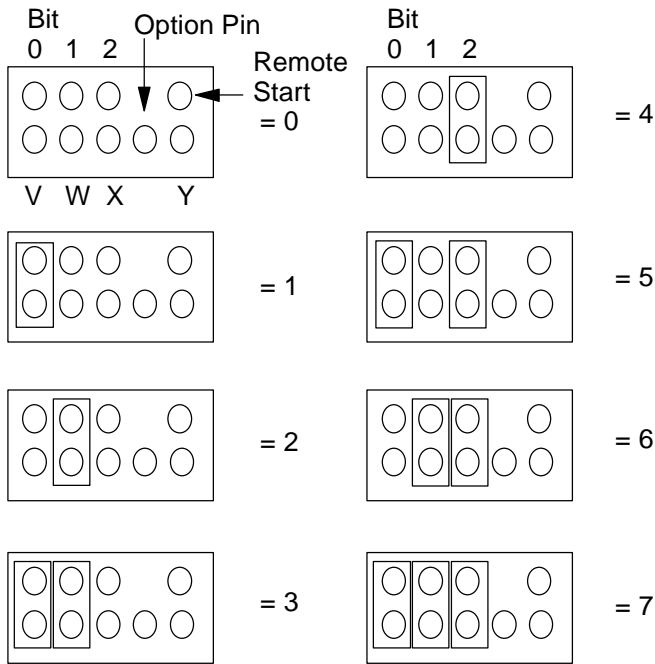

Figure 1 Option Block

With the Remote Start jumper in place the motor spins up when power is applied. With the Remote Start jumper removed the motor spins up when the drive is issued a Start Unit command.

During the power up sequence the option pin is interrogated. If it is grounded the pin remains an input. If it is not grounded it becomes an output, indicating Motor Active or Command Active depending on the state of the CMDAC bit in Mode Select page 0.

Note: As an input the option pin has several effects upon the SCSI function. Please refer to the 0661 SCSI Specification for details.

MODE SELECT OPTIONS

Certain "Mode Select" parameters are alterable via the SCSI "Mode Select" command. This allows several drive characteristics to be modified to optimize performance on any particular system. Refer to the 0661 SCSI Specification for detailed definition of Mode Select parameters.

Changeable parameters are:

Block Descriptor

Block length

Page 0

QPE (Qualify Post Error)

UQE (Untagged Queueing Enable)
DWD (Disable Write Disconnect)
Maximum Burst Length
ASDPE (Additional Save Data Pointer Enable)
RDDSS
CMDAC

Page 1

TB (Transfer Block)
RC (Read Continuous)
PER (Post Error)
DTE (Disable Transfer on Error)
DCR (Disable Correction)
Read Retry Count

Page 2

Read Buffer Full Ratio
Write Buffer Empty Ratio

Page 7

PER
DCR

Page 8

RCD (Read Cache Disable)

DATA ORGANIZATION

Capacity

Formatted (520 bytes/sector) 406 megabytes
Formatted (512 bytes/sector) 400 megabytes
Formatted (256 bytes/sector) 200 megabytes

Cylinders

Total cylinders	1201
User cylinders	1199
Data heads	14
Disks	8
Sectors per track	48
User sectors per drive	782576
Spare sectors per drive	21152
Sector size	256 or 512 or 520 bytes/sector

DC POWER REQUIREMENTS LIMITS

Power supplied to the drive must conform to the following limits:

+12 Volt Supply
 + or -5.0% (during run) - 7.0% +5.0% (during start)
 +5 Volt Supply
 + or -5.0%

+5V DC Idle Current

	<i>Nominal</i>	<i>Maximum</i>
	0.70 Amps	0.90 Amps

+12VDC Idle/Seek Current
 The current drawn (in Amps) from the 12 Volt supply is defined for seeking and steady state operations as follows

	<i>Nominal</i>	<i>Maximum</i>
Idle		
average	0.70	0.90
peak ripple		1.60
peak to peak		1.10
Seek		
average	1.20	1.40
peak ripple		2.7
peak to peak		2.25

+12VDC Start/Stop Current

	<i>Nominal</i>	<i>Maximum</i>
start		
(0-0.26 sec)	3.90 Amps	4.60 Amps
(0.26-1.5 sec)	2.90 Amps	3.30 Amps

Power Supply Ripple

<i>Voltage</i>	<i>Maximum</i>	<i>Notes</i>
+5VDC	100 mV peak-to-peak	0-10 MHz
+12VDC	150 mV peak-to-peak	0-10 MHz

Maximum Common Mode Noise
 300 mV peak-to-peak (0 to 100 MHz)

Note: Common mode noise is defined as the differential voltage between frame ground and electrical ground.

OPERATING ENVIRONMENT

The drive operates within its' performance limits when the following environment is maintained. Product life calculations are based on the nominal environment for a typical application.

Humidity:

Operating 8% to 80% noncondensing
Storage 5% to 80% noncondensing
Shipping 5% to 100% (applies at a packaged level)

Wet Bulb Temperature:

Operating 80 Degrees F (26.7 Degrees C) maximum
Shipping/Storage 85 Degrees F (29.4 Degrees C) maximum

Elevation:

Operating -1000 to 10000 feet
(-304 to 3048 meters)
Shipping/Storage -1000 to 30000 feet
(-304 to 9144 meters)

Temperature:

Operating ambient 50 to 122 Degrees F (10 to 50 Degrees C)
Operating casting 50 to 140 Degrees F (10 to 60 Degrees C) temperature
Operating casting Not to exceed 3.6 Degrees F (2 Degrees C) temperature delta (see note below)
Shipping -40 to 140 Degrees F (-40 to 60 Degrees C)
Storage 34 to 140 Degrees F (1.1 to 60 Degrees C)

Note: Measured between top and bottom of disk enclosure.

ELECTRICAL INTERFACE SPECIFICATIONS

The IBM OEM 0661 Model 467 Disk Drive uses single-ended drivers and receivers that permit cable lengths of up to 6 meters (19.68 feet).

Connectors

The drive has two connectors: one for power, the other for connecting to the SCSI bus.

Power

The DC power connector is designed to mate with AMP part number 1-480424-0 using AMP pins part number 350078-4 or their equivalent. Pin assignments are shown in Figure 2.

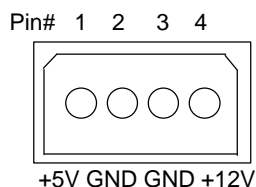

Figure 2 Power Connector Pin Assignments

SCSI Signal Connector

The SCSI signal connector is a 50-pin connector, Molex part number 70248 or equivalent, meeting ANSI/SCSI specifications.

SCSI Bus Terminators

The drive has no internal SCSI bus terminators. The user is responsible for properly terminating and powering the SCSI bus in the system.

AMP part number 88-4163-081-1, DATA MATE DM500-06-8, or equivalent external terminator may be used.

For a single-ended cable, a 50-conductor flat cable or a 25 twisted pair cable can be used, with a maximum length of 6.0 meters and a stub length not to exceed 0.1 meters.

The drive has an internal stub length of 0.077 meters. The SCSI bus cable must not add more than 0.023 meters additional stub length to remain compliant with ANSI.

SCSI Bus Electrical Characteristics

Note: The drive incorporated the Western Digital WD33C93A SCSI Interface Controller and conforms to the ANSI/SCSI Interface standard.

ELECTROMAGNETIC COMPATIBILITY

The Drive meets the following EMC requirements when installed in the user system and exercised with a random accessing routine at maximum data rate:

United States Federal Communication Commission (RCC) Rules and Regulations, Part 15, Subject J - Computer Devices "Class B Limits".

European Economic Community EEC directive #76/889 related to the control of radio frequency interference and the Verband Deutscher Elektrotechniker (VDE) requirements of Germany (GOP).

START AND STOP TIMES

Time	Nominal	Maximum
Start	27 sec	1 min
Stop	9 sec	12.5 sec

During the start sequence diagnostics are performed and are divided into two sections. Pre motor-start diagnostics test the static RAM (control store memory), post motor-start diagnostics test the data buffer, upload the code, perform channel testing and "Reassign in Progress" operations. For more information on diagnostics see the 0661 SCSI Specification. If a Reset is issued before the drive is ready, the power-on sequence starts again. Otherwise, when a Reset is issued the present state of the motor is not altered.

A timeout of one minute or more is recommended for the Start Unit command. This allows the system to take advantage of the extended ERP that the drive does in order to successfully start up.

Note: It is the integrators' responsibility to ensure that equipment into which this drive is fitted meets the relevant regulatory requirements (EMC, etc).

COOLING

This drive does require airflow in order to fulfill its' reliability performance. Please refer to Environmental section of the 0661-476 product specification for full details of the maximum allowable temperatures and measurement points. A summary of the measurements is given on the back page of this data sheet.

KNOWN INTEGRATION SOLUTIONS

The drive initiates negotiation for synchronous data transfer rate during the initialization sequence. This may cause problems which prevent attachment to some systems/SCSI controller cards.

Jumpering the option pin (B1) to ground on the jumper block prevents the drive sending the synchronous negotiation message.

However, other changes are also made to the drives behavior re error reporting and sense information returned. These are detailed in the Disk Drive SCSI specification

- NOTES -

- Attaching to NEXT Stations requires changes to particular parameters set in the Mode Select pages.

Setting up the drive to allow attachment is as follows:

Mode Select Page 0 byte 2 must be changed to 40

Mode Select Page 0 byte 3 must be changed to 80

- Attachment to the DEC 3100 system running VMS 5.4.2 or later versions requires changes to particular error recovery parameters set in the Mode Select pages.

Setting up drive to allow attachment is as follows:

Mode Select Page 1 byte 2 must be changed to 04.

Mode Select Page 7 byte 2 must be changed to 04.

- A number of Apple systems do not appear to accept the Unit Attention condition returned by the drive in response to the first SCSI command issued after power up or reset.

The 0661-467 cannot attach to these systems although there are a number of 3rd party device drivers which may overcome this limitation.

- To improve their performance many Apple systems make use of a "Blind Write" feature when writing to the data buffer on their SCSI interface card.

The 0661-467 is not compatible with this feature and system errors can occur during "Write" operations, particularly where large files are being transferred.

This feature must be disabled on the Apple system to allow successful drive attachment.

Troubleshooting

The drive reports status in response to the SCSI "Sense" command and this is a powerful troubleshooting tool on any drive whose failure mode still allows it to communicate. If the drive is interrupted by powering down during a format operation it will enter degraded mode. In this mode it will return a "Unit Attention" condition to most SCSI commands. Issuing a "Sense" Command immediately after issuing a "Test Unit Ready" Command will return sense data which indicates that the drive is in degraded mode. The way to recover the drive is to issue the SCSI "Format" command and allow the drive to format to completion.



PACKAGING: The drive must be protected against Electro-Static Discharge especially when being handled. The safest way to avoid damage is to put the drive in an anti static bag before ESD wrist straps, etc are removed.

Drives should only be shipped in approved containers, severe damage can be caused to the drive if the packaging does not adequately protect against the shock levels induced when a box is dropped. Consult the dealer if you do not have an approved shipping container.

This file was last updated on 12/14/94

MECHANICAL SPECIFICATIONS

This section details the mechanical specifications of the IBM OEM 0661 disk drive.

Weight

Approximately 2.2 pounds (1.0 kilograms)

Dimensions

	<i>U.S</i>	<i>S.I.Metric</i>
Height	1.62 in.	41.275 mm
Width	4.00 in	101.6 mm
Depth*	5.75 in.	146.0 mm

*The connectors exceed the depth dimension by 6.37 mm.

Clearances

A minimum of 2 mm clearance should be given to the top and bottom surfaces (except at the bottom mounting holes).

To assist cooling, it is recommended that a clearance of 6 mm be provided above and below the drive.

Precautions must be taken to avoid blocking any of the vent holes (on the side and ends of

the drive).

Mounting

The drive can be mounted in any of the following positions.

- Bottom side down
- Right side down
- Left side down
- Back end down

There are 4 mounting holes on the bottom, and 2 on each side of the drive.
(See diagram below for locations).

The torque applied to the mounting screws must not exceed 1.0 +/- 0.1 Newton meters.

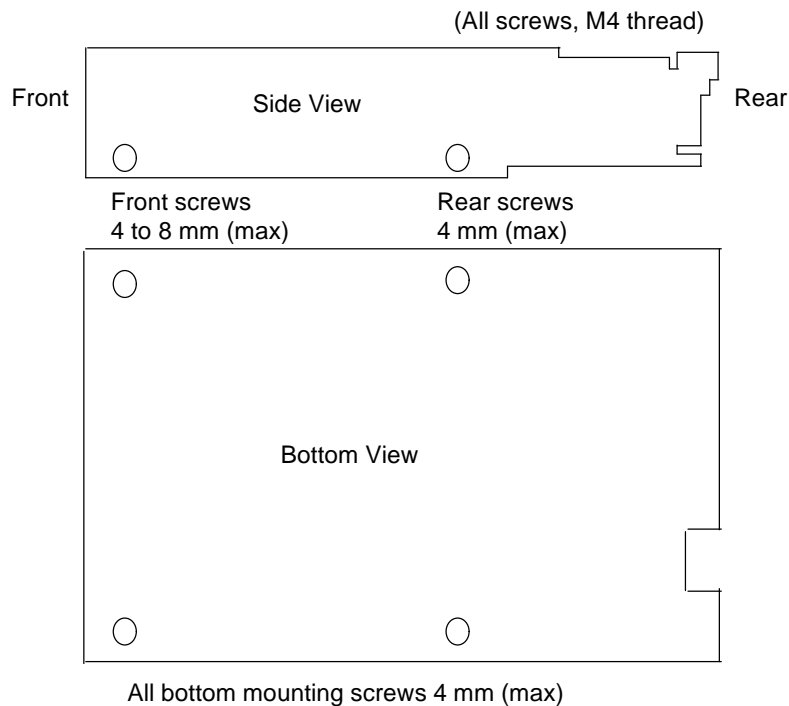

Note: Maximum screw lengths must not be exceeded.

TEMPERATURE MEASUREMENTS

Temperature measurements should be made at the points shown in the diagram, to ensure that the maximum values are not exceeded under any circumstances. Forced air

cooling may be required in order to achieve this.

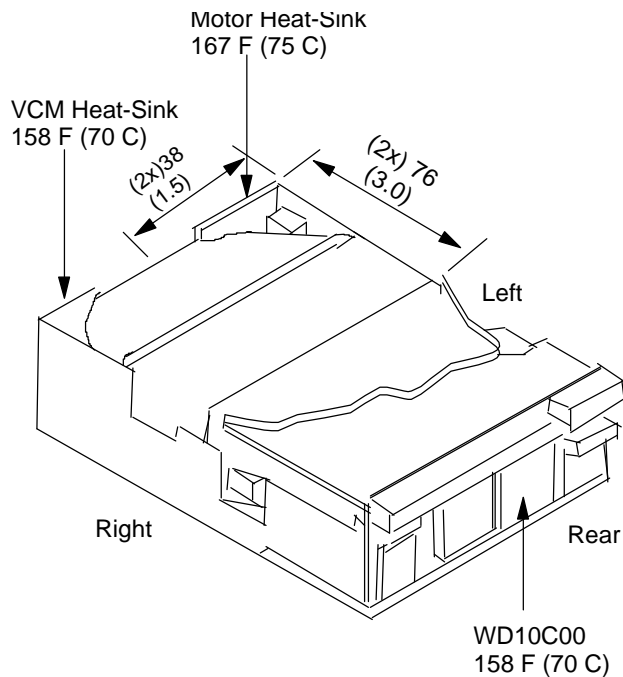

Figure 3 Temperature Measurement Points

Figure 3 defines where measurements should be made to determine module and casting temperatures, top side and bottom side (the difference between the two points is defined as the delta). There must be sufficient air flow through the drive so as not to exceed the casting and module temperature limits.

Temperature Gradient:

Operating	18 degrees F (10 degrees C) per hour
Shipping and storage	Below condensation

VIBRATION AND SHOCK

Operating Vibration

Due to the complexity of this subject we recommend that users contact the Distributor to discuss how to perform the required measurements if they believe this to be an area which requires evaluation.

Nonoperating Vibration

No damage occurs when vibration at the unpackaged drive does not exceed 0.5 G at swept sinusoidal frequencies from 2 to 200 Hz.

Operating Shock

The drive continues to operate, at the stated through-put, when subjected to a 5 G half sine wave shock pulse of 11 milliseconds duration.

No permanent damage occurs to the drive when subjected to a 10 G half sine wave shock pulse of 11 millisecond duration.

The shock pulses are applied in either direction in each of three mutually perpendicular axes, one axis at a time.

Nonoperating Shock

No damage will occur as long as the unpacked drive is not subjected to a square wave shock greater than a value of 35 Gs applied in all directions of the three axes for a period of 20 milliseconds, one direction at a time. (Front, Left side, Right side, Back).

AMP is a trade mark of
AMP Incorporated.

Molex is a trade mark of
Molex Incorporated.

DATA MATE is a trade mark of
AMP Incorporated.

Western Digital is a trade mark of
Western Digital Corporation.

NEXT is a trade mark of
NEXT corporation.

IBM OEM Europe
PO Box 6
Langstone Road
Havant
Hampshire
PO 9 ISA
United Kingdom
Telephone: (44) 705 486363

This data sheet is not a substitute for the full product specification, which should be used when detailed information is required.

Product Description data represents IBM's design objectives and is provided for comparative purposes; actual results may vary based on a variety of factors. This product data does not constitute a warranty. Questions regarding IBM's warranty terms or methodology used to derive this data should be referred to your IBM OEM representative. Data subject to change without notice.

