



Technical Information Manual

S52H-3381-00

PC 730 (Type 6877) and PC 750 (Type 6887)



Technical Information Manual

S52H-3381-00

PC 730 (Type 6877) and PC 750 (Type 6887)

Note

Before using this information and the product it supports, be sure to read the general information under Appendix B, "Notices and Trademarks" on page 52.

First Edition (June 1996)

The following paragraph does not apply to the United Kingdom or any country where such provisions are inconsistent with local law: INTERNATIONAL BUSINESS MACHINES CORPORATION PROVIDES THIS PUBLICATION "AS IS" WITHOUT WARRANTY OF ANY KIND, EITHER EXPRESS OR IMPLIED, INCLUDING, BUT NOT LIMITED TO, THE IMPLIED WARRANTIES OF MERCHANTABILITY OR FITNESS FOR A PARTICULAR PURPOSE. Some states do not allow disclaimer of express or implied warranties in certain transactions, therefore, this statement may not apply to you.

This publication could include technical inaccuracies or typographical errors. Changes are periodically made to the information herein; these changes will be incorporated in new editions of the publication. IBM may make improvements and/or changes in the product(s) and/or the program(s) described in this publication at any time.

It is possible that this publication may contain reference to, or information about, IBM products (machines and programs), programming, or services that are not announced in your country. Such references or information must not be construed to mean that IBM intends to announce such IBM products, programming, or services in your country.

Requests for technical information about IBM products should be made to your IBM reseller or IBM marketing representative.

IBM may have patents or pending patent applications covering subject matter in this document. The furnishing of this document does not give you any license to these patents. You can send license inquiries, in writing, to:

IBM Director of Licensing
IBM Corporation
500 Columbus Avenue
Thornwood, NY 10594
U.S.A.

© Copyright International Business Machines Corporation June 1996. All rights reserved.

Note to U.S. Government Users — Documentation related to restricted rights — Use, duplication or disclosure is subject to restrictions set forth in GSA ADP Schedule Contract with IBM Corp.

Contents

Preface	v
Related Publications	v
Manual Style	v
Signals	vi
Numerics	vi
Chapter 1. System Description	1
Personal Computer Description	2
System Overview	3
System Features	4
System Board	6
System Address Maps	7
Memory Map	7
Input/Output Address Map	7
DMA I/O Address Map	10
IRQ and DMA Channel Assignments	11
Interrupt Request Assignments (IRQ)	11
DMA Channel Assignments	11
Power Supply	12
Power Output Parameters	12
PC 730	12
PC 750	13
Component Outputs	14
Output Protection	15
Connector Description	15
Physical Specifications	16
PC 730	16
PC 750	17
Advanced Power Management (APM)	18
Chapter 2. Optional System Features	19
Audio Subsystem	20
DCC Connectors	20
Audio System Resources	20
Matrox Millennium Adapter	20
LAN Wake-Up	20
Wake Up On Ring	21
Wake Up on Alarm	21
PCMCIA and SCSI Devices	21
Chapter 3. Connectors and Jumpers	22
System Board Connectors	23
Diskette Drive Connector	23
Hard Disk Drive Connectors (Primary/Secondary)	24
ISA Connector	25
PCI Connectors	26
Power Supply Connectors	27
System Board Memory Connectors	28
Video Feature Connector	29
I/O Connectors	29

Infrared Connector	30
Keyboard and Auxiliary-Device Connectors	31
Serial Port Connectors	32
Parallel Port Connector	34
Display Connector	36
Chapter 4. Memory Subsystems	37
Memory-Module Description	38
Memory-Module Configurations	38
Cache Memory	39
Chapter 5. System Compatibility	40
Hardware Compatibility	41
Hardware Interrupts	41
Diskette Drives and Controller	42
Hard Disk Drives and Controller	43
Software Compatibility	43
Software Interrupts	43
Machine-Sensitive Programs	44
BIOS Compatibility	44
Chapter 6. Bus Architecture	45
Bus Architecture Descriptions	46
ISA Bus	46
PCI Bus	47
Expansion-Bus Features	47
Bus Voltage Levels	49
Appendix A. Error Codes	50
POST Error Codes	50
Beep Codes	51
Appendix B. Notices and Trademarks	52
Trademarks	52
Index	54

Figures

1.	PC System Board Devices, Features, and Options	4
2.	System Board Diagram	6
3.	System Memory Map	7
4.	I/O Address Map	7
5.	DMA I/O Addresses for Memory Addresses, Word Counts, and Command/Status Registers	10
6.	Interrupt Request Assignments	11
7.	DMA Channel Assignments	11
8.	AC Input Power Requirements	12
9.	Power Output Parameters (145 Watt)	12
10.	DC Output Parameters (200 Watt)	13
11.	Component Maximum Current	14
12.	Physical Specifications (PC 730)	16
13.	Physical Specifications (PC 750)	17
14.	Advanced Power Management Modes	18
15.	Audio System Resources	20
16.	Diskette Drive Connector Signal and Pin Assignments	23
17.	Hard Disk Drive Connector Signal and Pin Assignments	24
18.	I/O Channel (ISA bus) Connector	25
19.	PCI Connector Signal and Pin Assignments	26
20.	Power Supply Connector (Internal Devices) Signal and Pin Assignments	27
21.	Power Supply Connector (System Board) Signal and Pin Assignments	27
22.	Power Supply Connector (3.52 V dc) Signal and Pin Assignments	27
23.	System Board Memory Connector Signal and Pin Assignments	28
24.	VESA Feature Connector	29
25.	IR Connector Pin Assignments	30
26.	Auxiliary-Device Signal and Pin Assignments	31
27.	Keyboard Signal and Pin Assignments	31
28.	Serial Port Connector Signal and Pin Assignments	32
29.	Parallel Port Connector Signal and Pin Assignments	34
30.	Display Connector Signal and Pin Assignments	36
31.	Memory-Module Type, Speed, and Size	38
32.	System Memory Table	38
33.	L1 and L2 Cache	39
34.	5.25-Inch Diskette Drive Reading, Writing, and Formatting Capabilities	42
35.	3.5-Inch Diskette Drive Reading, Writing, and Formatting Capabilities	42
36.	POST Error Messages	50
37.	Beep Codes	51

Preface

This *Technical Information Manual* provides information for the IBM PC 730 (Type 6877) and the IBM PC 750 (Type 6887). It is intended for developers who want to provide hardware and software products to operate with these IBM computers and provides a more in-depth view of how these IBM computers work. Users of this publication should have an understanding of computer architecture and programming concepts.

Related Publications

The *Technical Information Manual* can be used with the following publications. These publications contain additional information about many of the subjects that are discussed in this manual and also provide additional information.

IBM publications:

- *Understanding Your Personal Computer PC 730 (Type 6877) and PC 750 (Type 6887)*
- *Using Your Personal Computer PC 730 (Type 6877) and PC 750 (Type 6887)*
- *Installing Options in Your Personal Computer PC 730 (Type 6877) and PC 750 (Type 6887)*
- *IBM Personal System/2 and Personal Computer BIOS Interface Technical Reference*
- *IBM Personal System/2 Hardware Interface Technical Reference—Common Interfaces*
- *IBM Personal System/2 ATA/IDE Fixed Disk Drives Technical Reference*
- *IBM Personal System/2 Hardware Interface Technical Reference—Architectures*

Other publications:

- *S3 Trio64V+*, published by S3 Incorporated, Santa Clara, CA
- *Intel Microprocessor and Peripheral Component Literature*, published by Intel Corporation, Santa Clara, CA
- *82420/82430 PCISet ISA and EISA Bridges*, published by Intel Corporation, Santa Clara, CA
- *82430 PCISet Cache/Memory Subsystem*, published by Intel Corporation, Santa Clara, CA
- *PCI Local Bus Specification*, published by the PCI Special Interest Group, Hillsboro, OR
- *Extended Capabilities Port: Specification Kit*, published by Microsoft Corporation, Redmond, WA
- *ANSI ATA-2 (AT Attachment)*

Manual Style

Warning: The term *reserved* describes certain signals, bits, and registers that should not be changed. Use of reserved areas can cause compatibility problems, loss of data, or permanent damage to the hardware. When the contents of a register are changed, the state of the reserved bits must be preserved. When possible, read the register first and change only the bits that must be changed.

Signals

In this manual, signals are represented in a small, all-capital-letter format (-ACK). A minus sign in front of the signal indicates that the signal is active low. No sign in front of the signal indicates that the signal is active high.

Numerics

In this manual, use of the letter “h” indicates a hexadecimal number. Also, when numerical modifiers such as “K”, “M” and “G” are used, they typically indicate powers of 2, not powers of 10 (unless expressing hard disk storage capacity). For example, 1 KB equals 1 024 bytes (2^{10}), 1 MB equals 1 048 576 bytes (2^{20}), and 1 GB equals 1 073 741 824 bytes (2^{30}).

When expressing storage capacity, MB equals 1 000 KB (1 024 000). The value is determined by counting the number of sectors and assuming that every two sectors equals 1 KB.

Note: The actual storage capacity available to the user can vary, depending on the operating system and other system requirements.

Chapter 1. System Description

Personal Computer Description	2
System Overview	3
System Features	4
System Board	6
System Address Maps	7
Memory Map	7
Input/Output Address Map	7
DMA I/O Address Map	10
IRQ and DMA Channel Assignments	11
Interrupt Request Assignments (IRQ)	11
DMA Channel Assignments	11
Power Supply	12
Power Output Parameters	12
PC 730	12
PC 750	13
Component Outputs	14
Output Protection	15
Connector Description	15
Physical Specifications	16
PC 730	16
PC 750	17
Advanced Power Management (APM)	18

Personal Computer Description

The IBM PC 730 (Type 6877) and PC 750 (Type 6887) is a versatile product designed to provide state-of-the-art computing power with room for growth in the future. Several model variations are available. The key features are:

- Intel Pentium microprocessor
- Up to 128 MB of system memory
- S3 Trio64V+ video subsystem
- 2 MB of video memory
- Industry-standard compatibility
- ISA/PCI I/O-bus compatibility
- ISA/PCI expansion slots
- Enhanced EIDE drives
- Bus-master EIDE controller
- Two 16550-UART serial ports (serial A and serial B)
- One infrared I/O port
- 256 KB of external L2 cache (expandable to 512 KB)
- Support for advanced power management
- EnergyStar compliant
- Support for Plug and Play adapters and monitors
- Security features
- Ready-to-configure (RTC) CD-ROM containing device drivers for all supported operating systems
- System unit packaging
 - The PC 730 has three expansion slots and three drive bays
 - The PC 750 has five expansion slots and five drive bays

System Overview

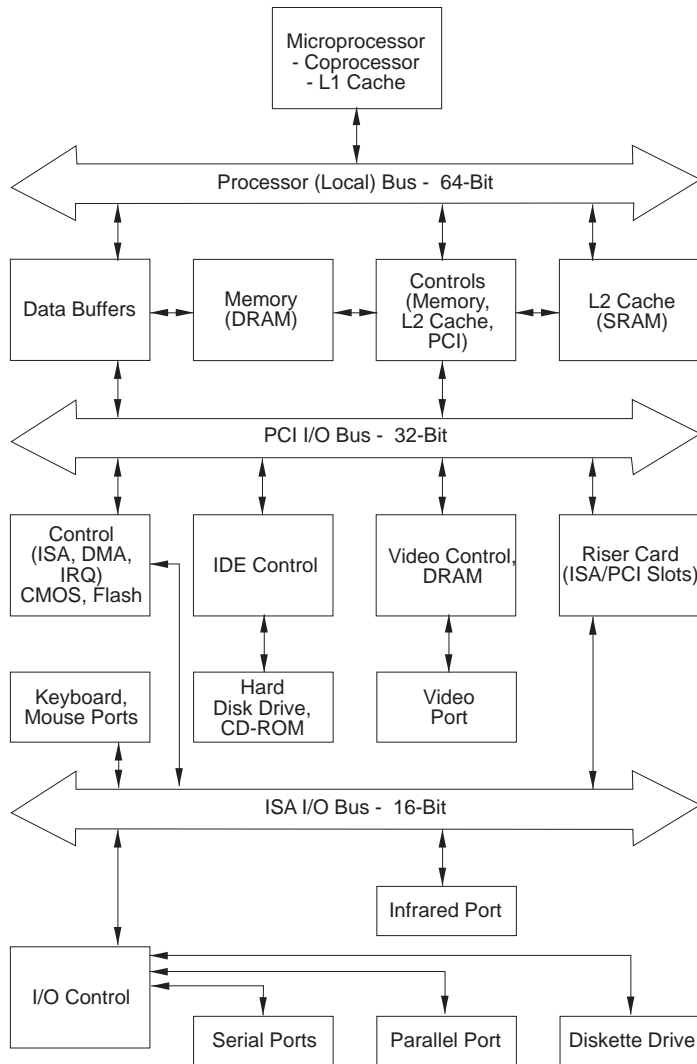

System Features

The following figure lists the devices and features for the PC 730 and PC 750 system board in the IBM 700 series personal computer family.

Figure 1 (Page 1 of 2). PC System Board Devices, Features, and Options

Device	Features
Microprocessor	Intel Pentium (100/133/166 MHz) <ul style="list-style-type: none"> • 32-bit address bus, 64-bit data bus • 8 KB internal (L1) write-through code cache • 8 KB internal (L1) write-back data cache • Superscalar architecture (two execution units) • Math coprocessor function included in the Pentium Microprocessor is upgradable for future Intel microprocessor technology
External Cache (L2)	256 KB synchronous write-back unified (code and data) L2 cache is upgradable to 512 KB (pipeline burst)
Video Subsystem	S3 Trio64V+ SVGA video controller <ul style="list-style-type: none"> • Plug and Play monitor support (DDC2B) • Advanced Power Management • Local peripheral bus (LPB) interface • 64-bit data path width on PCI-bus • Video streams processor • Integrated DAC • 64-bit graphics accelerator 2 MB of 60-ns EDO DRAM <ul style="list-style-type: none"> • Single-cycle EDO DRAM (deeper colors)
Bus Architecture	ISA/PCI-bus-compatible I/O expansion slots Synchronous 25/30/33 MHz PCI bus 50/60/66 MHz processor bus Integrated L2 cache controller
Flash ROM Subsystem	256 KB flash ROM for POST/BIOS
RAM Subsystem	16 MB standard DRAM, upgradable to 128 MB 60-ns fast page (FP) or extended data output (EDO); parity or non-parity, dynamic random access memory (DRAM) Four 72-pin SIMM sockets in two banks <ul style="list-style-type: none"> • SIMMs (4 MB, 8 MB, 16 MB, or 32 MB) • Matched pairs required in each bank One 168-pin DIMM socket in one bank <ul style="list-style-type: none"> • DIMMs (16 MB, 32 MB)
CMOS RAM Subsystem	128-byte CMOS RAM with real-time clock, calendar, and battery
ISA/PCI Bridge	ISA/PCI interface PCI bus-master EIDE interface ISA-compatible interrupt controller ISA-compatible DMA controller
DMA Controller	Seven AT-compatible DMA channels <ul style="list-style-type: none"> • Four 8-bit channels • Three 16-bit channels
Interrupt Controller	15 levels of system interrupts <ul style="list-style-type: none"> • AT-bus interrupts are edge triggered • PCI bus interrupts are level sensitive
System Timers	Channel 0–System timer Channel 1–Refresh generation Channel 2–Tone generation for speaker
Audio Subsystem	Mwave DSP data collaboration ISA adapter (optional) <ul style="list-style-type: none"> • Programmable DSP • 28.8 Kbps data/fax modem • Sound Blaster Pro compatibility • Front panel audio control

Figure 1 (Page 2 of 2). PC System Board Devices, Features, and Options

Device	Features
Diskette Drive Controller	<p>Controller supports two internal diskette drives</p> <ul style="list-style-type: none"> • A 3.5-in. diskette drive (1.44 MB and 2.88 MB) is standard • A 5.25-in. diskette drive (360 KB and 1.2 MB) is optional • A second 3.25-in. diskette drive (1.44 MB and 2.88 MB) is optional and requires a 3.5-in. conversion kit for a 5.25-in. bay <p>FIFO operations</p>
Keyboard/Auxiliary-Device Controller	<p>101-key or 102-key keyboard Keyboard connector Auxiliary-device connector Password security</p>
Parallel Port Controller	<p>One ECP parallel port Supports standard I/O mode, extended capabilities port (ECP) mode, and enhanced parallel port (EPP) mode</p>
Serial Port Controller	<p>Two 16550-UART serial ports (Serial A and B) Note: Serial B is disabled if infrared port is used</p>
High Speed Infrared (HSIR) Controller	<p>One HSIR port Infrared Data Association (IrDa) interface Infrared transceiver (optional)</p>
Hard Disk Drive Controller	<p>Controller supports four EIDE devices PCI bus-master EIDE interface</p> <ul style="list-style-type: none"> • Two PCI bus-master channels • One channel for each EIDE connector (primary and secondary) • SCSI hard disk drives require a PCI SCSI adapter
Power	<p>145/200 watt power supplies</p> <ul style="list-style-type: none"> • PC 730: 145 W, 115/230 V ac, 50/60 Hz • PC 750: 200 W, 115/230 V ac, 50/60 Hz <p>Built-in overload and surge protection Advanced Power Management</p>
Security	<p>Power-on password Administrator password Startup sequence control Unattended Start mode Diskette I/O control Hard disk I/O control Lockable cover Software-readable hardware IDs Tamper switch</p>

System Board

The system board might look slightly different from the one shown.

Note: A diagram of the system board, including switch and jumper settings, is attached to the underside of the computer top cover.

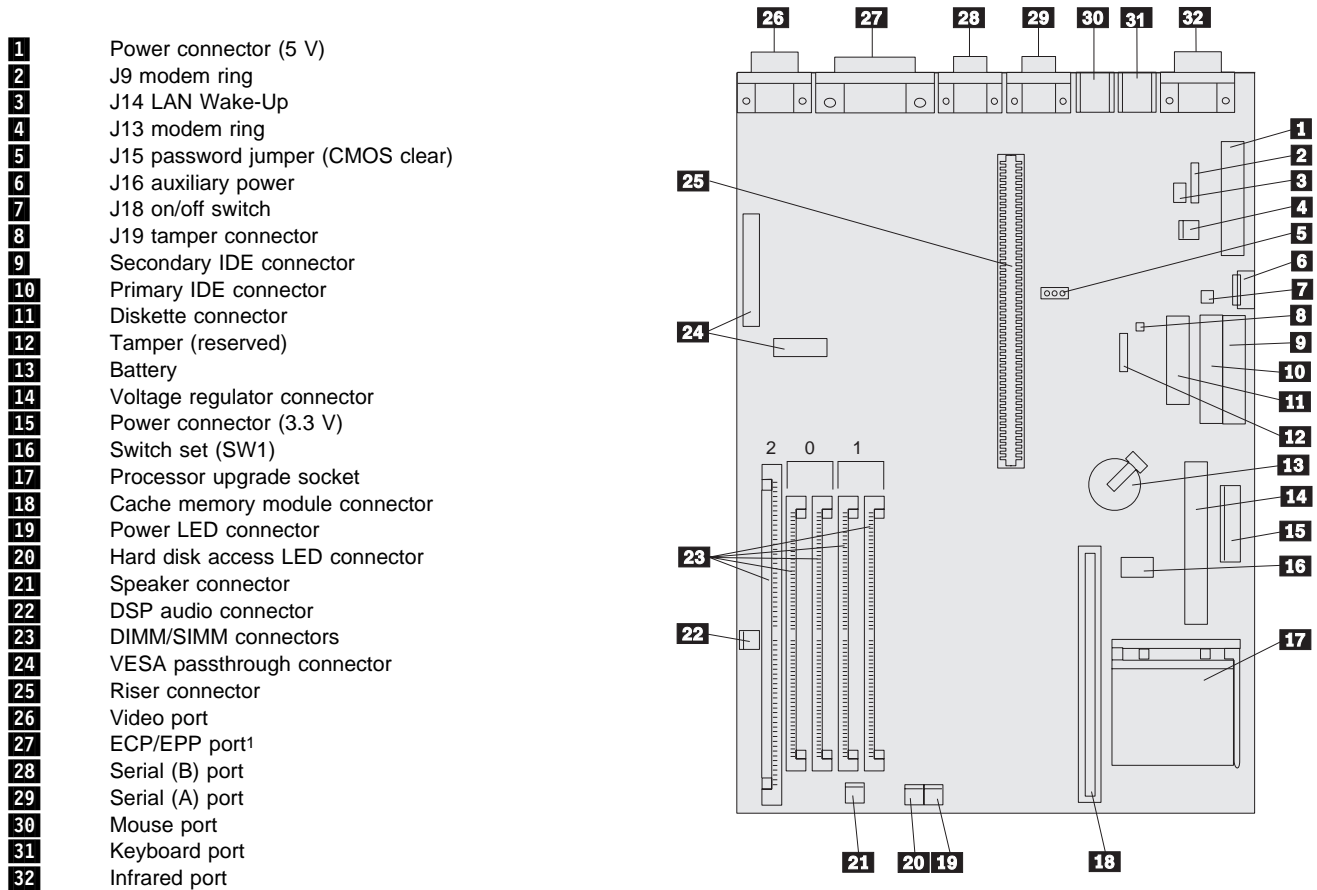

Figure 2. System Board Diagram

¹ Extended capabilities port (ECP) and enhanced parallel port (EPP)

System Address Maps

Memory Map

The first 640 KB of system board RAM is mapped starting at address 0000000h. A 256-byte area and a 1 KB area of this RAM are reserved for BIOS data areas. Memory can be mapped differently if POST detects an error. See the section about BIOS data areas in the *IBM Personal System/2 and Personal Computer BIOS Interface Technical Reference* for details.

Note: After POST is completed, portions of the 64 KB segment starting at memory address E0000h, are available for upper memory blocks and adapters.

<i>Figure 3. System Memory Map</i>		
Address Range (hex)	Size	Description
00000000–0007FFFF	512 KB	Conventional
00080000–0009FBFF	127 KB	Extended conventional
0009FC00–0009FFFF	1 KB	Extended BIOS data
000A0000–000BFFFF	128 KB	S3 Trio64V+
000C0000–000C7FFF	32 KB	S3 Trio64V+ ROM BIOS (shadowed)
000D8000–000DFFFF	96 KB	ISA/PCI space; available to ISA adapter ROMs
000E0000–000FFFFF	128 KB	System ROM BIOS (ISA bus, shadowed) E000:0-E800:0 used for Advanced Power Management (APM)
00100000–00FFFFFF	15 MB	ISA/PCI space
01000000–07FFFFFF	111 MB	PCI space
08000000–72FFFFFF	1712 MB	PCI space
07300000–737FFFFFF	8 MB	S3 Trio64V+ linear frame buffer
73800000–FFFDFFFF	2247.9 MB	PCI space
FFFE0000–FFFFFFF	128 KB	System ROM BIOS (ISA bus)

Input/Output Address Map

The following figures list the system board I/O address maps. Any addresses that are not shown are reserved.

<i>Figure 4 (Page 1 of 3). I/O Address Map</i>	
Address (Hex)	Device
0000–000F	DMA 1
0020–003F	Interrupt controller 1
0040–0043	Timer 1
0044–0047	Available I/O for ISA/PCI bus
0048–0049	Rapid Resume Advanced Power Management registers
004A–004B, bits 7,6	CPU speed registers
004C–005F	Available I/O for ISA/PCI bus
0060	Keyboard controller data byte
0061	System Port B
0062–0063	Available I/O for ISA/PCI bus
0064	Keyboard controller, command and status byte
0065–006F	Available I/O for ISA/PCI bus
0070, bit 7	Enable/disable NMI
0070, bits 6:0	Real time clock address
0071	Real time clock data
0072–007F	Available I/O for ISA/PCI bus
0077	DCC setup/presence detect
0078	GPIO CPU speed detect
0079	National 87306 GPIO, A17 for flash
007A	National 87306 GPIO
007C–007F	L2 Cache ID, tamper EEPROM, SMI/PCI IRQ enable
0080	POST Checkpoint register
0080-008F	DMA page register

Chapter 1. System Description

Figure 4 (Page 2 of 3). I/O Address Map

Address (Hex)	Device
0090–0091	Available I/O for ISA/PCI bus
0092	System Port A (not supported)
0093	Available I/O for ISA/PCI bus
0094	Reserved
0095–009F	Available I/O for ISA/PCI bus
00A0–00BF	Interrupt controller 2
00C0–00DE	DMA 2
00DF–00ED	Available I/O for ISA/PCI bus
00EE	Reserved
00EF	Reserved
00F0	Coprocessor busy–Clear
00F1	Coprocessor reset
00F2–00F3	Available I/O for ISA/PCI bus
00F4	Slow CPU
00F5	Fast CPU
00F6–00FF	Available I/O for ISA/PCI bus
0100–0105	Reserved riser
0106–016F	Available I/O for ISA/PCI bus
0130–013F	Default for data collaboration card (DCC)
0170–0177	IDE channel 1
01B0–01BF	Alternate for data collaboration card (DCC)
01F0–01F7	IDE channel 0
01F8–021F	Available I/O for ISA/PCI bus
0220–0227	National 87306, serial port 3 or 4
0228–0277	Available I/O for ISA/PCI bus
0230–023F	Alternate for data collaboration card (DCC)
0278–027F	National 87306, parallel port 3
0280–02E7	Available I/O for ISA/PCI bus
02B0–02BF	Alternate for data collaboration card (DCC)
02E8–02EF	National 87306, serial port 3 or 4
02F0–02F7	Available I/O for ISA/PCI bus
02F8–02FF	National 87306, serial port 2 (system board)
0300–0337	Available I/O for ISA/PCI bus
0338–033F	National 87306, serial port 3 or 4
0340–0375	Available I/O for ISA/PCI bus
0376–0377	IDE channel 1
0377, bit 7	IDE, diskette change
0378–037F	National 87306, parallel port 2
0380–0387	Available I/O for ISA/PCI bus
0388	Available I/O for ISA/PCI bus
0389	Available I/O for ISA/PCI bus
038A	Available I/O for ISA/PCI bus
038B	Available I/O for ISA/PCI bus
038C–03BB	Available I/O for ISA/PCI bus
03B4–03BB	S3 Trio64V+
03BC–03BE	National 87306, parallel port 1 (system board)
03BF–03DF	S3 Trio64V+
03E0–03E7	Available I/O for ISA/PCI bus
03E8–03EF	National 87306, serial port 3 or 4
03F0–03F5	National 87306, diskette channel 0
03F6	IDE channel 0
03F7, bit 7	IDE, diskette change
03F7, bits 6:0	IDE channel 0
03F8–03FF	National 87306, serial port 1 (system board)
0400–052F	Available I/O for ISA/PCI bus
0530–0537	Available I/O for ISA/PCI bus
0530–0537	Available I/O for ISA/PCI bus
0CF8–0CFB	PCI configuration address register
0CFC–0CFF	PCI configuration data registers
0D00–0E7F	Available I/O for ISA/PCI bus
0E80–0E87	Available I/O for ISA/PCI bus
0E88–0F3F	Available I/O for ISA/PCI bus
0F40–0F47	Available I/O for ISA/PCI bus

Figure 4 (Page 3 of 3). I/O Address Map

Address (Hex)	Device
0F47–042E7	Available I/O for ISA/PCI bus
42E8	S3 Trio64V+
42E9–4AE7	Available I/O for ISA/PCI bus
4AE8	S3 Trio64V+
4AE9–82E7	Available I/O for ISA/PCI bus
82E8	S3 Trio64V+
82E9–86E7	Available I/O for ISA/PCI bus
86E8	S3 Trio64V+
86E9–8AE7	Available I/O for ISA/PCI bus
8AE8	S3 Trio64V+
8AE9–8EE7	Available I/O for ISA/PCI bus
8EE8	S3 Trio64V+
8EE9–92E7	Available I/O for ISA/PCI bus
92E8	S3 Trio64V+
92E9–96E7	Available I/O for ISA/PCI bus
96E8	S3 Trio64V+
96E9–9AE7	Available I/O for ISA/PCI bus
9AE8	S3 Trio64V+
9AE9–9EE7	Available I/O for ISA/PCI bus
9EE8	S3 Trio64V+
9EE9–A2E7	Available I/O for ISA/PCI bus
A2E8	S3 Trio64V+
A2E9–A6E7	Available I/O for ISA/PCI bus
A6E8	S3 Trio64V+
A6E9–AAE7	Available I/O for ISA/PCI bus
AAE8	S3 Trio64V+
AAE9–B2E7	Available I/O for ISA/PCI bus
B2E8	S3 Trio64V+
B2E9–B6E7	Available I/O for ISA/PCI bus
B6E8	S3 Trio64V+
B6E9–BAE7	Available I/O for ISA/PCI bus
BAE8	S3 Trio64V+
BAE9–BEE7	Available I/O for ISA/PCI bus
BEE8	S3 Trio64V+
BEE9–E2E7	Available I/O for ISA/PCI bus
E2E8	S3 Trio64V+
E2E9	Available I/O for ISA/PCI bus
E2EA	S3 Trio64V+
E2EB–FFFF	Available I/O for ISA/PCI bus

DMA I/O Address Map

Figure 5. DMA I/O Addresses for Memory Addresses, Word Counts, and Command/Status Registers

Address (hex)	Description	Bits	Byte Pointer
0000	Channel 0, Memory Address register	00–15	Yes
0001	Channel 0, Transfer Count register	00–15	Yes
0002	Channel 1, Memory Address register	00–15	Yes
0003	Channel 1, Transfer Count register	00–15	Yes
0004	Channel 2, Memory Address register	00–15	Yes
0005	Channel 2, Transfer Count register	00–15	Yes
0006	Channel 3, Memory Address register	00–15	Yes
0007	Channel 3, Transfer Count register	00–15	Yes
0008	Channels 0–3, Read Status/Write Command register	00–07	
0009	Channels 0–3, Write Request register	00–02	
000A	Channels 0–3, Write Single Mask register bits	00–02	
000B	Channels 0–3, Mode register (write)	00–07	
000C	Channels 0–3, Clear byte pointer (write)	N/A	
000D	Channels 0–3, Master clear (write)/temp (read)	00–07	
000E	Channels 0–3, Clear Mask register (write)	00–03	
000F	Channels 0–3, Write All Mask register bits	00–03	
0081	Channel 2, Page Table Address register ¹	00–07	
0082	Channel 3, Page Table Address register ¹	00–07	
0083	Channel 1, Page Table Address register ¹	00–07	
0087	Channel 0, Page Table Address register ¹	00–07	
0089	Channel 6, Page Table Address register ¹	00–07	
008A	Channel 7, Page Table Address register ¹	00–07	
008B	Channel 5, Page Table Address register ¹	00–07	
008F	Channel 4, Page Table Address/Refresh register	00–07	
00C0	Channel 4, Memory Address register	00–15	Yes
00C2	Channel 4, Transfer Count register	00–15	Yes
00C4	Channel 5, Memory Address register	00–15	Yes
00C6	Channel 5, Transfer Count register	00–15	Yes
00C8	Channel 6, Memory Address register	00–15	Yes
00CA	Channel 6, Transfer Count register	00–15	Yes
00CC	Channel 7, Memory Address register	00–15	Yes
00CE	Channel 7, Transfer Count register	00–15	Yes
00D0	Channels 4–7, Read Status/Write Command register	00–07	
00D2	Channels 4–7, Write Request register	00–02	
00D4	Channels 4–7, Write Single Mask register bit	00–02	
00D6	Channels 4–7, Mode register (write)	00–07	
00D8	Channels 4–7, Clear byte pointer (write)	N/A	
00DA	Channels 4–7, Master clear (write)/temp (read)	00–07	
00DC	Channels 4–7, Clear Mask register (write)	00–03	
00DE	Channels 4–7, Write All Mask register bits	00–03	
00DF	Channels 5–7, 8- or 16-bit mode select	00–07	

¹ Upper byte of Memory Address register

IRQ and DMA Channel Assignments

The following figures list the interrupt request (IRQ) and direct memory access (DMA) channel assignments.

Interrupt Request Assignments (IRQ)

Figure 6. Interrupt Request Assignments

Interrupt Request (IRQ)	System Resource
NMI	Critical system error
SMI	System/power management interrupt
0	Reserved (internal timer)
1	Reserved (keyboard buffer full)
2	Reserved (cascade interrupt from slave)
3	Serial port 2 ¹
4	Serial port 1 ²
5	Parallel port 2 ¹
6	Diskette controller ²
7	Parallel port 1 or business audio if installed ²
8	Reserved (real-time clock)
9	Video adapter (if installed) or business audio ¹
10	ISA/PCI bus or business audio.
11	ISA/PCI bus or business audio.
12	Mouse port ¹
13	Reserved (math coprocessor)
14	IDE Channel 1 ¹
15	IDE Channel 2 ²

¹ If not assigned, this resource is available for ISA/PCI bus.
² If not assigned, this resource is available for ISA bus.

DMA Channel Assignments

Figure 7. DMA Channel Assignments

DMA Channel	Data Width	System Resource
0	8 bits	Business audio ¹
1	8 bits	Business audio or LAN ¹
2	8 bits	Reserved (diskette drive)
3	8 bits	Business audio or ECP parallel port ¹
4		Reserved (cascade channel)
5	16 bits	ISA bus
6	16 bits	ISA bus
7	16 bits	ISA bus

¹ If not assigned, this resource is available for ISA bus.

Power Supply

The power supply converts the ac input voltage into four dc output voltages and provides power for the following:

- System board
- Adapters
- Internal DASD drives
- Keyboard and auxiliary devices

The power supply requirements are supplied by a 145-watt (PC 730) or 200-watt (PC 750) power supply. The following figure shows the input power specifications. The power available for each component with the system is shown in Figure 11 on page 14.

<i>Figure 8. AC Input Power Requirements</i>	
Specification	Measurements
Input voltage (range is switch selected; sine wave input is required) Low range High range	110 (min)–127 (max) V ac 200 (min)–240 (max) V ac
Input frequency	50 Hz \pm 3 Hz or 60 Hz \pm 3 Hz

Power Output Parameters

The power supply dc outputs shown in the following figures include the current supply capability of all the connectors including system board, DASD, PCI, and auxiliary outputs.

PC 730

<i>Figure 9. Power Output Parameters (145 Watt)</i>			
Output Voltage	Regulation	Minimum Current (amps)	Maximum Current (amps)
+5 volts	+5% to -4%	1.5 A	18.0 A
+12 volts	+5% to -4%	0.2 A	4.2 A
-12 volts	+10% to -9%	0.0 A	0.4 A
-5 volts	+5% to -4%	0.0 A	0.3 A
+3.52 volts	+2.5% to -2.5%	0.0 A	10.0 A
+5 volt (auxiliary)	+5% to -10%	0.0 A	.02 A

Note: Simultaneous loading of +5 V and +3.52 V must not exceed 90 watts.

PC 750

<i>Figure 10. DC Output Parameters (200 Watt)</i>			
Output Voltage	Regulation	Minimum Current (amps)	Maximum Current (amps)
+5 volts	+5% to -4%	1.5 A	20.0 A
+12 volts	+5% to -4%	0.2 A	8.0 A
-12 volts	+10% to -9%	0.0 A	0.5 A
-5 volts	+5% to -4%	0.0 A	0.5 A
+3.52 volts	+2.5% to -2.5%	0.0 A	20.0 A
+5 volt (auxiliary)	+5% to -10%	0.0 A	.02 A

Note: Simultaneous loading of +5 V and +3.52 V must not exceed 90 watts maximum.

The power supply provides 180 watts of continuous power and 200 watts at peak power to the system board and peripheral devices. It provides a fan that cools both the power supply and the microprocessor by drawing external air through the power supply and blowing it onto the microprocessor. A single connector provides the voltages required by the system board, including +3.52 V dc. Five connectors are provided for attachment of peripheral devices.

Component Outputs

The power supply provides separate voltage sources for the system board and internal storage devices. The following figure shows the approximate power that is provided for system components. Many components draw less current than the maximum shown.

Figure 11. Component Maximum Current

Supply Voltage (V dc)	Maximum Current (mA)	Regulation Limits
System Board:		
+3.52 V dc	3000 mA	+2.5% to -2.5%
+5.0 V dc	4000 mA	+5.0% to -5.0%
+12.0 V dc	25.0 mA	+5.0% to -5.0%
-12.0 V dc	25.0 mA	+10.0% to -9.0%
Keyboard Port:		
+5.0 V dc	275 mA	+5.0% to -5.0%
Auxiliary Device Port:		
+5.0 V dc	300 mA	+5.0% to -5.0%
AT-Bus Adapters (Per Slot):		
+5.0 V dc	4500 mA	+5.0% to -5.0%
-5.0 V dc	200 mA	+5.0% to -5.0%
+12.0 V dc	1500 mA	+5.0% to -5.0%
-12.0 V dc	300 mA	+5.0% to -5.0%
PCI-bus Adapters (Per Slot)¹:		
+5.0 V dc	5000 mA	+5.0% to -4.0%
+3.52 V dc	5000 mA	±300 mV
Internal DASD:		
+5.0 V dc	1400 mA	+5.0% to -5.0%
+12.0 V dc	1500 mA	+5.0% to -5.0%

¹ For each PCI connector, the maximum power consumption is rated at 25 watts for +5 V and +3.52 V combined.

Note: Some adapters and hard disk drives draw more current than the recommended limits. These adapters and drives can be installed in the system; however, the power supply will shut down if the total power used exceeds the maximum power that is available.

Output Protection

The power supply protects against output overcurrent, overvoltage, and short circuits. Please see the power supply specifications for details.

A short circuit that is placed on any dc output (between outputs or between an output and dc return) latches all dc outputs into a shutdown state, with no damage to the power supply.

If this shutdown state occurs, the power supply returns to normal operation only after the fault has been removed and the power switch has been turned off for at least one second.

If an overvoltage fault occurs (in the power supply), the power supply latches all dc outputs into a shutdown state before any output exceeds 130% of the nominal value of the power supply.

Connector Description

The power supply has up to five 4-pin connectors for internal devices. The total power used by the connectors must not exceed the amount shown in Figure 11 on page 14. Signal and pin assignments are shown on page 27.

Physical Specifications

The following figure describe the physical specifications. Each mechanical package is described separately.

PC 730

Figure 12. Physical Specifications (PC 730)

Size	
Width	360 mm (14.2 in.)
Depth	450 mm (17.7 in.)
Height	130 mm (5.1 in.)
Weight	
Minimum configuration	8.6 kg (19.0 lb)
Maximum configuration (fully populated with typical options)	10.4 kg (23.0 lb)
Cables	
Power cable	1.8 m (6 ft)
Keyboard cable	3.05 m (10 ft)
Air Temperature	
System on	10.0 to 32.0°C (50 to 90°F)
System off	10.0 to 43.0°C (50 to 110°F)
Humidity	
System on	8% to 80%
System off	8% to 80%
Maximum Altitude¹	2133.6 m (7000 ft)
Heat Output	
Minimum configuration	35 W (120 Btu per hour)
Maximum configuration ²	200 W (685 Btu per hour)
Electrical	
Input voltage (range is switch selected; sine wave input is required)	
Low range	110 (min) to 127 (max) V ac
High range	200 (min) to 240 (max) V ac
Frequency	50 ± 3 Hz or 60 ± 3 Hz
Input, in kilovolt-ampere (kVA)	
Minimum configuration	0.08 kVA
Maximum configuration	0.30 kVA
Electromagnetic Compatibility	FCC Class B

¹ This is the maximum altitude at which the specified air temperatures apply. At higher altitudes, the maximum air temperatures are lower than those specified.

² Based on the 145-watt maximum capacity of the system power supply.

PC 750

Figure 13. Physical Specifications (PC 750)

Size	
Width	420 mm (16.5 in.)
Depth	448 mm (17.6 in.)
Height	160 mm (6.3 in.)
Weight	
Minimum configuration	12.7 Kg (28.0 lb)
Maximum configuration (fully populated with typical options)	14.1 Kg (31.1 lb)
Cables	
Power cable	1.8 m (6 ft)
Keyboard cable	3.05 m (10 ft)
Air Temperature	
System on	10.0 to 32.0°C (50 to 90°F)
System off	10.0 to 43.0°C (50 to 110°F)
Humidity	
System on	8% to 80%
System off	8% to 80%
Maximum Altitude ¹	2133.6 m (7000 ft)
Heat Output	
Minimum configuration	35 W (120 Btu per hour)
Maximum configuration ²	310 W (1060 Btu per hour)
Electrical	
Input voltage (range is switch selected; sine wave input is required)	
Low range	110 (min) to 127 (max) V ac
High range	200 (min) to 240 (max) V ac
Frequency	50 ± 3 Hz or 60 ± 3 Hz
Input, in kilovolt-ampere (kVA)	
Minimum configuration	0.08 kVA
Maximum configuration	0.52 kVA
Electromagnetic Compatibility	FCC Class B
¹ This is the maximum altitude at which the specified air temperatures apply. At higher altitudes, the maximum air temperatures are lower than those specified.	
² Based on the 200-watt maximum capacity of the system power supply.	

Advanced Power Management (APM)

The computers come with built-in energy-saving capabilities. Advanced Power Management (APM) is a feature that reduces the power consumption of systems when they are not being used. APM, when enabled, initiates reduced-power modes for the monitor, microprocessor, and hard disk drive after a specified period of inactivity.

The following figure summarizes APM modes.

Figure 14. Advanced Power Management Modes

Mode	Power	Response
On (Ready)	System is at full power	Standard operation
On (Standby)	System is at reduced power	Any use of keyboard, mouse, or hard disk drive restores full power
Off	System is powered off	Power switch restores full power

The BIOS supports APM V1.0 AND V1.1. This enables the system to enter a power managed state, which reduces the power drawn from the ac wall outlet. Advanced Power Management is enabled through the Configuration/Setup Utility program and is controlled by the individual operating system.

Chapter 2. Optional System Features

Audio Subsystem	20
DCC Connectors	20
Audio System Resources	20
Matrox Millennium Adapter	20
LAN Wake-Up	20
Wake Up On Ring	21
Wake Up on Alarm	21
PCMCIA and SCSI Devices	21

Audio Subsystem

Some models have a front audio interface panel and an ISA data collaboration card (DCC) featuring an Mwave digital-signal processor (DSP) subsystem.

The DCC provides the following support:

- Programmable DSP
- 28.8 Kbps data/fax modem
- Simultaneous record and playback of CD quality audio
- Compatible with Sound Blaster Pro
- Front panel headphone and microphone jacks with volume control

DCC Connectors

The DCC consists of a base card and a daughter card attached to the base card. The base card contains the DSP and audio circuits. The daughter card contains the communication interface required to access the telephone network. Four cables connect the DCC to the system board.

Audio System Resources

Figure 15. Audio System Resources

Resource	Resource Assignment
ROM	none
RAM	none
I/O (hex)	77, 130-13F, 1B0-1BF, 230-23F, 2B0-2BF, 300, 330
IRQ	3, 4, 5, 7, 9, 10, 11
DMA	0, 1, 3, 5

Matrox Millennium Adapter

The optional *Matrox Millennium Graphics Adapter* takes advantage of 64-bit graphics engine technology, which provides very fast graphics and video acceleration. It is VGA- and VESA-compatible (SVGA, DPMS, DDC).

LAN Wake-Up

Some models are configured for LAN connection with an Ethernet adapter or a token ring adapter. These models are enabled for LAN Wake-Up using LAN adapters that support the LAN Wake-Up feature.

The LAN Wake-Up feature allows the personal computer to be powered up in an unattended mode, with keyboard and mouse input locked, when a specific LAN frame is passed to the PC through the LAN. This feature works in coordination with Advanced Power Management (APM).

Wake Up On Ring

When this option is enabled, the computer is turned on automatically when a ring is detected on a modem. Two options control this feature:

- **Serial Ring Detect:** Set this option to **Enabled** if the computer has an external modem connected to the serial port.
 - **Modem Ring Detect:** Set this option to **Enabled** if the computer has an internal modem.
-

Wake Up on Alarm

With this option, you can specify a date and time at which the computer will be turned on automatically. This can be either a single event or a daily event.

PCMCIA and SCSI Devices

Personal Computer Memory Card International Association (PCMCIA) and Small Computer System Interface (SCSI) devices support can be added with optional adapters.

Chapter 3. Connectors and Jumpers

System Board Connectors	23
Diskette Drive Connector	23
Hard Disk Drive Connectors (Primary/Secondary)	24
ISA Connector	25
PCI Connectors	26
Power Supply Connectors	27
System Board Memory Connectors	28
Video Feature Connector	29
I/O Connectors	29
Infrared Connector	30
Keyboard and Auxiliary-Device Connectors	31
Serial Port Connectors	32
Serial-Port Setup	32
Data Collaboration	33
Parallel Port Connector	34
Parallel-Port Setup	34
Parallel-Port Modes	35
Display Connector	36

System Board Connectors

The following figures show the connectors that are available on the system board and riser card.

Diskette Drive Connector

The computer has a 34-pin connector that supports the attachment of up to two diskette drives. The following figure shows the signal and pin assignments for the system board diskette drive connector.

Figure 16. Diskette Drive Connector Signal and Pin Assignments

Pin	Signal	Pin	Signal
1	Ground	2	High density select
3	Ground	4	Not connected
5	Ground or key	6	-Data rate select 0
7	Ground	8	-Index
9	Ground	10	-Motor enable 0
11	Ground	12	-Drive select 1
13	Ground	14	-Drive select 0
15	Ground	16	-Motor enable 1
17	Ground or MSEN1	18	-Direction in
19	Ground	20	-Step
21	Ground	22	-Write data
23	Ground	24	-Write enable
25	Ground	26	-Track 0
27	Ground or MSEN0	28	-Write protect
29	Ground	30	-Read data
31	Ground	32	-Head 1 select
33	Ground	34	-Diskette change

Hard Disk Drive Connectors (Primary/Secondary)

The computer has a dedicated I/O channel for connecting a hard disk drive. The signals that are provided by this connector include the 16-bit data bus, address lines A0 to A2, IRQ, and -IO CS16. These signals operate in the same way as the normal I/O-channel signals. The interface to the hard disk drive complies with *ANSI ATA-2 (AT Attachment)*.

The address decode logic for the hard disk drive is on the system board. On a valid decode of A0 through A15 equal to 01F0h through 01F7h, -HFCS0 (0170h through 0177h, -HFCS2 for a secondary hard disk drive) goes active. On a valid decode of A0 through A15 equal to 03F6h through 03F7h, -HFCS1 (0376h through 0377h, -HFCS3 for a secondary hard disk drive) goes active.

The following figure shows the signal and pin assignments for the hard disk drive connector.

Figure 17. Hard Disk Drive Connector Signal and Pin Assignments

Pin	Signal	Pin	Signal
1	-RESET	2	Ground
3	Data bus bit 7	4	Data bus bit 8
5	Data bus bit 6	6	Data bus bit 9
7	Data bus bit 5	8	Data bus bit 10
9	Data bus bit 4	10	Data bus bit 11
11	Data bus bit 3	12	Data bus bit 12
13	Data bus bit 2	14	Data bus bit 13
15	Data bus bit 1	16	Data bus bit 14
17	Data bus bit 0	18	Data bus bit 15
19	Ground	20	Key (Reserved)
21	DRQ0/DRQ1	22	Ground
23	-IO Write	24	Ground
25	-IO Read	26	Ground
27	IO Channel Ready	28	VCC pullup
29	DACK0/DACK1	30	Ground
31	IRQ14/IRQ15	32	VCC pullup
33	Device address A1	34	Ground
35	Device address A0	36	Device address A2
37	-HFCS0	38	-HFCS1
39	Activity #	40	Ground

ISA Connector

The I/O channel (ISA bus) is buffered to provide sufficient drive for the 98-pin connectors, assuming two low-power Schottky (LS) loads per slot.

The following figure shows the signal and pin assignments for the I/O channel connectors.

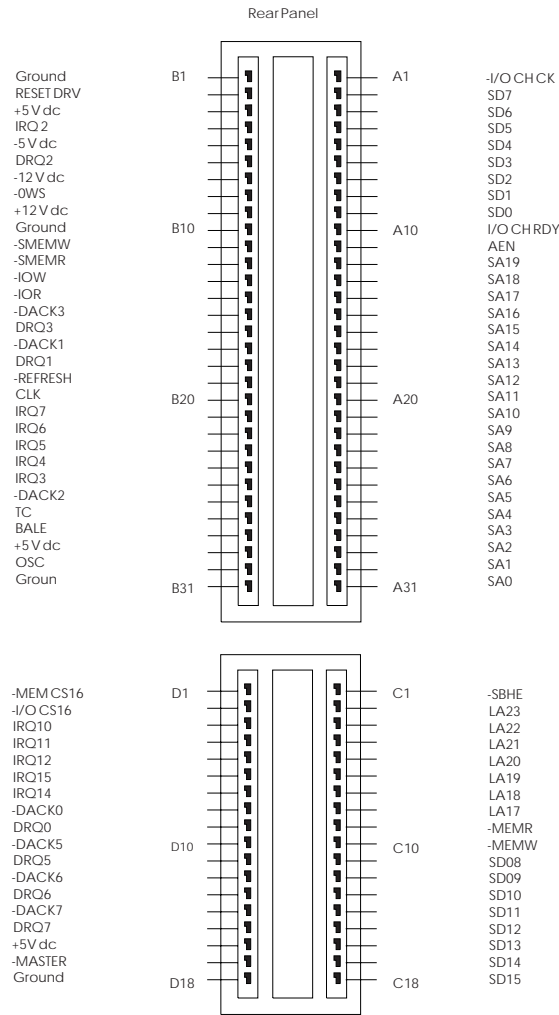

Figure 18. I/O Channel (ISA bus) Connector

PCI Connectors

The peripheral component interconnect (PCI) connector is a 124-pin connector. Personal computers with PCI riser cards support the 32-bit 5-V dc local-bus signalling environment that is defined in the *PCI Local Bus Specification*. The following figure shows the signal and pin assignments for the PCI connector.

Note: 3.52 V dc is supplied through an optional 5 V dc to 3.52 V dc regulator.

Figure 19 (Page 1 of 2). PCI Connector Signal and Pin Assignments

Pin	Signal	Pin	Signal
1 A	TRST#	32 A	Address 16
2 A	+12 V dc	33 A	+3.52 V dc
3 A	TMS	34 A	FRAME#
4 A	TDI	35 A	Ground
5 A	+5 V dc	36 A	TRDY#
6 A	INTA#	37 A	Ground
7 A	INTC#	38 A	STOP#
8 A	+5 V dc	39 A	+3.52 V dc
9 A	Reserved	40 A	SDONE
10 A	+5 V dc (I/O)	41 A	SBO#
11 A	Reserved	42 A	Ground
12 A	Ground	43 A	PAR
13 A	Ground	44 A	Address/Data 15
14 A	Reserved	45 A	+3.52 V dc
15 A	RST#	46 A	Address/Data 13
16 A	+5 V dc (I/O)	47 A	Address/Data 11
17 A	GNT#	48 A	Ground
18 A	Ground	49 A	Address/Data 9
19 A	Reserved	50 A	Connector key
20 A	Address/Data 30	51 A	Connector key
21 A	+3.52 V dc	52 A	C/BE 0"#
22 A	Address/Data 28	53 A	+3.52 V dc
23 A	Address/Data 26	54 A	Address/Data 6
24 A	Ground	55 A	Address/Data 4
25 A	Address/Data 24	56 A	Ground
26 A	IDSEL	57 A	Address/Data 2
27 A	+3.52 V dc	58 A	Address/Data 0
28 A	Address/Data 22	59 A	+5 V dc (I/O)
29 A	Address/Data 20	60 A	REQ64#
30 A	Ground	61 A	+5 V dc
31 A	Address/Data 18	62 A	+5 V dc
1 B	-12 V dc	32 B	Address/Data 17
2 B	TCK	33 B	C/BE 2"#
3 B	Ground	34 B	Ground
4 B	TDO	35 B	IRDY#
5 B	+5 V dc	36 B	+3.52 V dc
6 B	+5 V dc	37 B	DEVSEL#
7 B	INTB#	38 B	Ground
8 B	INTD#	39 B	LOCK#
9 B	PRSNT1#	40 B	PERR#
10 B	Reserved	41 B	+3.52 V dc
11 B	PRSNT2	42 B	SERR#
12 B	Ground	43 B	+3.52 V dc
13 B	Ground	44 B	C/BE 1"#
14 B	Reserved	45 B	Address/Data 14
15 B	Ground	46 B	Ground
16 B	CLK	47 B	Address/Data 12
17 B	Ground	48 B	Address/Data 10
18 B	REQ#	49 B	Ground
19 B	+5 V dc (I/O)	50 B	Connector key
20 B	Address/Data 31	51 B	Connector key
21 B	Address/Data 29	52 B	Address/Data 8
22 B	Ground	53 B	Address/Data 7

Figure 19 (Page 2 of 2). PCI Connector Signal and Pin Assignments

Pin	Signal	Pin	Signal
23 B	Address/Data 27	54 B	+3.52 V dc
24 B	Address/Data 25	55 B	Address/Data 5
25 B	+3.52 V dc	56 B	Address/Data 3
26 B	C/BE 3"#	57 B	Ground
27 B	Address/Data 23	58 B	Address/Data 1
28 B	Ground	59 B	+5 V dc (I/O)
29 B	Address/Data 21	60 B	ACK64#
30 B	Address/Data 19	61 B	+5 V dc
31 B	+3.52 V dc	62 B	+5 V dc

Power Supply Connectors

The power supply utilizes 4-pin connectors for internal devices. The total power used by the connectors must not exceed the amount shown in Figure 11 on page 14.

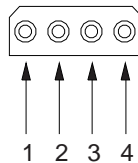

Figure 20. Power Supply Connector (Internal Devices) Signal and Pin Assignments

Pin	Signal	Pin	Signal
1	+12 V dc	3	Ground
2	Ground	4	+5 V dc

The computer has a 12-pin power supply connector. The following figure shows the signal and pin assignments for the system board power supply connector.

Figure 21. Power Supply Connector (System Board) Signal and Pin Assignments

Pin	Signal	Pin	Signal
1	Power good (+5 V dc)	2	+5 V dc
3	+12 V dc	4	-12 V dc
5	Ground	6	Ground
7	Ground	8	Ground
9	-5 V dc	10	+5 V dc
11	+5 V dc	12	+5 V dc

The computer has an additional 6-pin power supply connector that plugs into the riser card. The following figure shows the signal and pin assignments for the system board power supply connector.

Figure 22. Power Supply Connector (3.52 V dc) Signal and Pin Assignments

Pin	Signal	Pin	Signal
1	Ground	2	Ground
3	Ground	4	+3.52 V dc
5	+3.52 V dc	6	+3.52 V dc

System Board Memory Connectors

The following figure shows the signal and pin assignments for the 72-pin system board memory connectors. Data bits 0 through 15 are the low word, and data bits 16 through 31 are the high word.

Figure 23. System Board Memory Connector Signal and Pin Assignments

Pin	Signal	Pin	Signal
1	Ground	37	Parity 1
2	Data 0	38	Parity 3
3	Data 16	39	Ground
4	Data 1	40	Column address strobe 0
5	Data 17	41	Column address strobe 2
6	Data 2	42	Column address strobe 3
7	Data 18	43	Column address strobe 1
8	Data 3	44	Row address strobe 0
9	Data 19	45	Row address strobe 1
10	+5 V dc	46	Reserved
11	Reserved	47	Write enable
12	Address 0	48	Reserved
13	Address 1	49	Data 8
14	Address 2	50	Data 24
15	Address 3	51	Data 9
16	Address 4	52	Data 25
17	Address 5	53	Data 10
18	Address 6	54	Data 26
19	Address 10	55	Data 11
20	Data 4	56	Data 27
21	Data 20	57	Data 12
22	Data 5	58	Data 28
23	Data 21	59	+5 V dc
24	Data 6	60	Data 29
25	Data 22	61	Data 13
26	Data 7	62	Data 30
27	Data 23	63	Data 14
28	Address 7	64	Data 31
29	Reserved	65	Data 15
30	+5 V dc	66	Reserved
31	Address 8	67	Reserved
32	Address 9	68	Reserved
33	Row address strobe 3	69	Reserved
34	Row address strobe 2	70	Reserved
35	Parity 2	71	Reserved
36	Parity 0	72	Ground

Video Feature Connector

The computer has a 26-pin connector that supports the attachment of additional video features. The following figure shows the signal and pin assignments for the video feature connector.

Figure 24. VESA Feature Connector

Pin	Signal	Pin	Signal
1	Ground	2	Data 0
3	Ground	4	Data 1
5	Ground	6	Data 2
7	Data enable	8	Data 3
9	Sync enable	10	Data 4
11	PCLK enable	12	Data 5
13	Not used	14	Data 6
15	Ground	16	Data 7
17	Ground	18	PCLK
19	Ground	20	BLANK
21	Ground	22	HSYNC
23	Not used	24	VSYNC
25	Ground	26	Ground

I/O Connectors

The standard I/O device connectors include:

- A keyboard connector
- A mouse connector
- Two serial connectors (one port is disabled if infrared is used)
- An infrared (IR) transceiver module connector
- A parallel connector
- A monitor connector

The computer might also include:

- An internal modem
- A data collaboration adapter (modem, fax, voice mail, and audio)
- A LAN adapter
- A Matrox Millennium graphics adapter

Each I/O connector on the back panel of the computer is identified by a symbol.

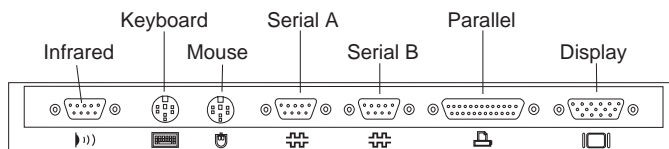

I/O Device Connectors

Infrared Connector

The computer comes with an infrared (IR) port for connecting an optional infrared transceiver module. The infrared transceiver allows wireless communication between the personal computer and other infrared-capable computers and printers.

The IR connector on the back of the computer is a 9-pin, female, D-shell connector. The transceiver plugs into this connector and provides a link of up to one meter at a rate of 115 kilobits-per-second (Kbps). The IR connector uses any of the same four port assignments as the serial port.

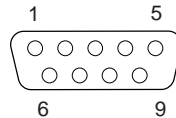

The following list shows the pin numbers and signal names assigned to this connector.

Pin	Signal
1	IR transmitted data (output)
2	Signal ground
3	Reserved
4	IR module select 0
5	IR module select 1
6	IR received data (input)
7	Voltage (5 V)
8	IR module select 2
9	Reserved

Note: When the IR port is used, Serial B is disabled.

Keyboard and Auxiliary-Device Connectors

The keyboard and auxiliary-device connectors use 6-pin miniature DIN connectors.

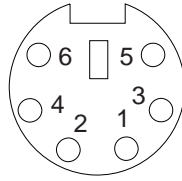

Figure 26. Auxiliary-Device Signal and Pin Assignments

Pin	I/O	Signal Name
1	I/O	Data
2	NA	Reserved
3	NA	Ground
4	NA	+5 V dc
5	I/O	Clock
6	NA	Reserved

Figure 27. Keyboard Signal and Pin Assignments

Pin	I/O	Signal Name
1	I/O	Data
2	NA	Aux data on keyboard connector
3	NA	Ground
4	NA	+5 V dc
5	I/O	Clock
6	NA	Aux clock on keyboard connector

Serial Port Connectors

The two serial connectors on the back of the computer use a 9-pin, male D-shell connector and pin assignments defined for RS-232D. The voltage levels are EIA only. Current loop interface is not supported.

The following figure shows the signal and pin assignments for the serial port connector in a communication environment.

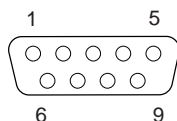

Figure 28. Serial Port Connector Signal and Pin Assignments

Pin	I/O	Signal Name	Pin	I/O	Signal Name
1	I	Data carrier detect	6	I	Data set ready
2	I	Receive data	7	O	Request to send
3	O	Transmit data	8	I	Clear to send
4	O	Data terminal read	9	I	Ring indicator
7	NA	Signal ground			

Use Serial A or Serial B for high-speed modem and printer connections, or for devices such as a mouse or other pointing device.

Note: When the IR port is used, Serial B is disabled.

The serial ports transfer data one bit at a time (serially), at speeds ranging from 300 to 345 600 bits per second (bps). The transfer rate is also referred to as *baud rate*. The serial ports on the computer are 16550-UART (universal asynchronous receiver/transmitter) compatible so they can support high-speed modems.

Serial-Port Setup

Each serial connector or adapter in the computer can use any of four available port settings, provided that a different setting is used for each. The settings include the port address (in hexadecimal) and the IRQ (interrupt request line), which determines how the microprocessor responds to an interrupt from the serial port. The four available port settings, in sequential order, are:

- 3F8h-IRQ 3 or 4
- 2F8h-IRQ 3 or 4
- 3E8h-IRQ 3 or 4
- 2E8h-IRQ 3 or 4

There is no direct relationship among the port connectors, the four available port settings, and the four COM numbers. When the computer is started, the power-on self-test (POST) assigns COM numbers to the port addresses that are actually in use at the time. POST goes down the list of addresses sequentially to assign COM numbers to each address in use by a serial device. If an address is not in use, a COM number is not assigned. POST assigns the next available COM number to the next address in use.

The port addresses and IRQ for Serial A and Serial B are preset at the factory to:

Serial A: 3F8h-IRQ 4

Serial B: 2F8h-IRQ 3

POST assigns COM numbers to Serial A and Serial B during startup:

Serial A: 3F8h-IRQ 4 (COM1)

Serial B: 2F8h-IRQ 3 (COM2)

However, if the computer comes with an internal modem, the factory settings and COM assignments are:

Serial A: 3F8h-IRQ 4 (COM1)

Serial B: 2F8h-IRQ 3 (COM2)

Modem: 3E8h-IRQ 5 (COM3)

The port address and IRQ settings for Serial A and Serial B can be viewed using the Configuration/Setup Utility program. The COM numbers are not shown on the setup screens; however, one of the diagnostic programs available with your computer can be used to view them.

Data Collaboration

Some models include a data collaboration card (DCC), which combines an internal modem and audio adapter. The modem is a 28 800-bps data modem with 14 400-bps send-and-receive fax capabilities.

The modem adapter has two telephone jacks on the back of the adapter.

The modem is set at the factory to communicate with the computer through the COM3 port using the standard address and IRQ 5. If necessary, the serial-port setting can be changed using the Configuration/Setup Utility program.

The audio functions provided by the DCC include the ability to record and play back standard wave (.WAV) files. The adapter also can be set up to emulate a Sound Blaster adapter. This feature is set at the factory at address 220h, IRQ 9, and DMA 0. These can be changed using the Configuration/Setup Utility program.

The adapter also combines audio features with the modem functions to provide a speaker phone and telephone answering machine.

Parallel Port Connector

The parallel port connector is a standard 25-pin D-shell connector. The following figure shows the signal and pin assignments for the parallel port connector.

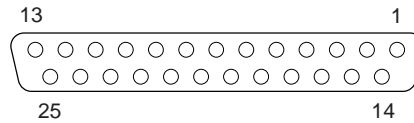

Figure 29. Parallel Port Connector Signal and Pin Assignments

Pin	I/O	Signal Name	Pin	I/O	Signal Name
1	O	-STROBE	14	O	-AUTO FD XT
2	I/O	Data bit 0	15	I	-ERROR
3	I/O	Data bit 1	16	O	-INIT
4	I/O	Data bit 2	17	O	-SLCT IN
5	I/O	Data bit 3	18	NA	Ground
6	I/O	Data bit 4	19	NA	Ground
7	I/O	Data bit 5	20	NA	Ground
8	I/O	Data bit 6	21	NA	Ground
9	I/O	Data bit 7	22	NA	Ground
10	I	-ACK	23	NA	Ground
11	I	BUSY	24	NA	Ground
12	I	PE	25	NA	Ground
13	I	SLCT			

The parallel port supports extended, high-speed modes, which means that it can transfer data up to 10 times as fast as a standard parallel port.

Parallel-Port Setup

Each parallel connector or adapter on your computer can use any of three available port settings, provided that a different setting is used for each. The settings include the port address (in hexadecimal) and the interrupt request line (IRQ), which determines how the microprocessor responds to an interrupt from the parallel port. The three available port settings, in sequential order, are the following:

- 3BCh-IRQ 5 or 7
- 378h-IRQ 5 or 7
- 278h-IRQ 5 or 7

There is no direct relationship among the three available port settings and the three LPT numbers. When you start the computer, the POST program assigns LPT numbers to the port addresses that are actually in use at the time. POST goes down the list of addresses sequentially to assign LPT numbers to each address in use by a parallel device. If an address is not in use, an LPT number is not assigned to it. POST assigns the next available LPT number to the next address in use.

The port address and IRQ setting for the built-in parallel port is preset at the factory to:

Built-in port: 3BCh-IRQ 7

POST assigns an LPT number to the built-in parallel port during startup:

Built-in port: 3BCh-IRQ 7 (LPT1)

If you add another parallel adapter that uses the next sequential address, POST assigns LPT numbers as follows:

Built-in port: 3BCh-IRQ 7 (LPT1)

Adapter port: 378h-IRQ 5 (LPT2)

The port address and IRQ setting for the built-in parallel port can be viewed using the Configuration/Setup Utility program. The LPT number are not shown on the configuration screen; however, one of the diagnostic programs available with your computer can be used to view them.

The parallel-port setting must be changed if you use ECP, EPP, or ECP/EPP modes because 3BCh-IRQ 7 cannot be used for these modes. The setting can be changed using the Configuration Setup Utility program.

Parallel-Port Modes

The parallel port can operate in five different modes. One is a *standard*, unidirectional mode; the other four are *extended*, bidirectional modes that provide additional function and higher performance. Refer to the documentation that comes with printers and other parallel devices to determine the appropriate parallel mode to use and required device drivers.

Standard	This <i>AT-compatible mode</i> is the default mode. In this mode, the parallel port is limited to writing information to the device attached to it. This mode can be used with most IBM-compatible parallel printers.
Bidirectional	This <i>PS/2-compatible mode</i> is a bidirectional mode used for data transfer to other PC systems and supported devices.
ECP	The <i>extended capabilities port (ECP)</i> mode is a high-performance, bidirectional mode that uses direct memory access (DMA) for data transfer to a high-speed printer or other devices.
EPP	The <i>enhanced parallel port (EPP)</i> mode is a high-performance, bidirectional mode that has capabilities similar to ECP mode; the main difference is that EPP data transfers are processor-initiated instead of DMA. EPP supports the connection of up to eight external devices such as hard disk drives, CD-ROM drives, tape drives, diskette drives, and a printer to the parallel port. These devices can be connected to each other in a <i>daisy-chain</i> arrangement, or they can be connected through an external multiplexor. The attachment of multiple devices requires device drivers supplied by the device manufacturers.
ECP/EPP	This mode combines the capabilities of the ECP and EPP modes. Select this mode to connect both ECP and EPP devices to the parallel port.

Select the mode of operation for the parallel port using the Configuration Setup Utility program.

Display Connector

The computer has a 15-pin display connector. The following figure shows the signal and pin assignments for the system board display connector.

Figure 30. Display Connector Signal and Pin Assignments

Pin	Signal	Pin	Signal
1	Red (out)	2	Green (out)
3	Blue (out)	4	Not used
5	Ground	6	Red ground
7	Green ground	8	Blue ground
9	+5 V (DDC2B)	10	Ground
11	Not used	12	DDC2B serial data (I/O)
13	Horizontal sync (out)	14	Vertical sync (out)
15	DDC2B clock (I/O)		

Chapter 4. Memory Subsystems

Memory-Module Description 38
Memory-Module Configurations 38
Cache Memory 39

Memory-Module Description

The computer has four SIMM connectors and one DIMM connector. After memory modules are installed, the Plug and Play feature of the Configuration/Setup Utility program automatically detects the additional memory modules.

Notes:

1. Memory modules can have a maximum height of 1.2 inches.
2. Install only parity SIMMs and DIMMs to enable parity.
3. A mix of parity and non-parity SIMMs and DIMMs will be configured as non-parity.
4. A mix of extended-data output (EDO) and fast page (FP) SIMMs and DIMMs can be installed if matched pairs are installed in each bank.
5. The computer uses industry-standard 60-ns 72-pin tin-lead SIMMs and 168-pin gold-lead DIMMs.

Memory-Module Configurations

The following shows the typical memory-module configurations.

Figure 31. Memory-Module Type, Speed, and Size

Type	Speed	Memory-Module Size
SIMM	60 ns	4 MB, 8 MB, 16 MB, 32 MB
DIMM	60 ns	8 MB, 16 MB, 32 MB

Figure 32. System Memory Table

Total Memory	Bank 0 SIMM 3,4	Bank 1 SIMM 1,2	Bank 2 DIMM
16 MB	0,0	0,0	16
16 MB	4,4	4,4	0
24 MB	0,0	4,4	16
24 MB	4,4	0,0	16
32 MB	0,0	0,0	32
32 MB	8,8	8,8	0
40 MB	4,4	8,8	16
40 MB	0,0	4,4	32
48 MB	4,4	4,4	32
64 MB	8,8	8,8	32
72 MB	4,4	16,16	32
80 MB	8,8	16,16	32
96 MB	16,16	16,16	32
128 MB	16,16	32,32	32

Cache Memory

Cache memory is a RAM storage location between the microprocessor and system memory. The microprocessor has a 16 KB L1 (internal) cache. The computer also supports up to 512 KB of L2 (external) cache. The following shows the cache supported.

<i>Figure 33. L1 and L2 Cache</i>		
L1 Cache Standard	L2 Cache Standard	L2 Cache Maximum
16 KB	256 KB	512 KB

Chapter 5. System Compatibility

Hardware Compatibility	41
Hardware Interrupts	41
Diskette Drives and Controller	42
Hard Disk Drives and Controller	43
Software Compatibility	43
Software Interrupts	43
Machine-Sensitive Programs	44
BIOS Compatibility	44

Hardware Compatibility

This section briefly discusses hardware, software, and BIOS compatibility issues that must be considered when designing application programs.

Many of the interfaces are the same as those used by the IBM Personal Computer AT. In most cases, the command and status organization of these interfaces is maintained.

The functional interfaces are compatible with the following interfaces:

- The Intel 8259 interrupt controllers (edge-triggered mode).
- The National Semiconductor NS16450 and NS16550A serial communication controllers.
- The Motorola MC146818 Time of Day Clock command and status (CMOS reorganized).
- The Intel 8254 timer, driven from a 1.193 MHz clock (channels 0, 1, and 2).
- The Intel 8237 DMA controller, except for the Command and Request registers and the Rotate and Mask functions. The Mode register is partially supported.
- The Intel 8272 or 82077 diskette drive controllers.
- The Intel 8042 keyboard controller at addresses 0060h and 0064h.
- All video standards using VGA, EGA, CGA, MDA, and Hercules modes.
- The parallel printer ports (Parallel 1, Parallel 2, and Parallel 3) in compatibility mode.

Use the following information to develop application programs for personal computer products. Whenever possible, use BIOS as an interface to hardware to provide maximum compatibility and portability of applications among systems.

Hardware Interrupts

Hardware interrupts are level-sensitive in systems using PCI bus architecture and are edge-triggered in systems using the personal computer type I/O architecture. The interrupt controller clears its in-service register bit when the interrupt routine sends an End-of-Interrupt (EOI) command to the controller. The EOI command is sent regardless of whether the incoming interrupt request to the controller is active or inactive.

In systems using level-sensitive interrupts, the interrupt-in-progress latch is readable at an I/O-address bit position. This latch is read during the interrupt service routine and might be reset by the read operation or it might require an explicit reset.

Note: For performance and latency considerations, designers might want to limit the number of devices sharing an interrupt level.

Chapter 5. System Compatibility

The interrupt controller in systems using level-sensitive interrupts requires that the interrupt request be inactive at the time the EOI command is sent; otherwise, a new interrupt request will be detected. To avoid this, a level-sensitive interrupt handler must clear the interrupt condition (usually by a read or write operation to an I/O port on the device causing the interrupt). After processing the interrupt, the interrupt handler:

1. Clears the interrupt
2. Waits one I/O delay
3. Sends the EOI
4. Waits one I/O delay
5. Enables the interrupt through the Set Interrupt Enable Flag command

In systems using level-sensitive interrupts, hardware prevents the interrupt controllers from being set to the edge-triggered mode. In systems using edge-triggered interrupts, hardware prevents the interrupt controllers from being set to the level-sensitive mode.

Hardware interrupt IRQ9 is defined as the replacement interrupt level for the cascade level IRQ2. Program interrupt sharing is implemented on IRQ2, interrupt 0Ah. The following processing occurs to maintain compatibility with the IRQ2 used by IBM Personal Computer products:

1. A device drives the interrupt request active on IRQ2 of the channel.
2. This interrupt request is mapped in hardware to IRQ9 input on the second interrupt controller.
3. When the interrupt occurs, the system microprocessor passes control to the IRQ9 (interrupt 71h) interrupt handler.
4. This interrupt handler performs an EOI command to the second interrupt controller and passes control to the IRQ2 (interrupt 0Ah) interrupt handler.
5. This IRQ2 interrupt handler, when handling the interrupt, causes the device to reset the interrupt request before performing an EOI command to the master interrupt controller that finishes servicing the IRQ2 request.

Diskette Drives and Controller

The following figures show the reading, writing, and formatting capabilities of each type of diskette drive.

<i>Figure 34. 5.25-Inch Diskette Drive Reading, Writing, and Formatting Capabilities</i>			
Diskette Drive Type	160/180 KB Mode	320/360 KB Mode	1.2 MB Mode
5.25-inch diskette drive:			
Single sided (48 TPI)	RWF	—	—
Double sided (48 TPI)	RWF	RWF	—
High capacity (1.2 MB)	RWF	RWF	RWF
R = Read W = Write F = Format			

<i>Figure 35. 3.5-Inch Diskette Drive Reading, Writing, and Formatting Capabilities</i>			
Diskette Drive Type	720 KB Mode	1.44 MB Mode	2.88 MB Mode
3.5-inch diskette drive:			
1.44 MB drive	RWF	RWF	—
2.88 MB drive	RWF	RWF	RWF
R = Read W = Write F = Format			

Notes:

1. Do not use 5.25-inch diskettes that are designed for the 1.2MB mode in either a 160/180 KB or 320/360 KB diskette drive.
2. Low-density 5.25-inch diskettes that are written to or formatted by a high-capacity 1.2 MB diskette drive can be reliably read only by another 1.2 MB diskette drive.
3. Do not use 3.5-inch diskettes that are designed for the 2.88 MB mode in a 1.44MB diskette drive.

Copy Protection

The following methods of copy protection might not work in systems using the 3.5-inch 1.44 MB diskette drive.

- Bypassing BIOS routines:
 - Data transfer rate: BIOS selects the proper data transfer rate for the media being used.
 - Diskette parameter table: Copy protection, which creates its own diskette parameter table, might not work in these drives.
- Diskette drive controls:
 - Rotational speed: The time between two events in a diskette drive is a function of the controller.
 - Access time: Diskette BIOS routines must set the track-to-track access time for the different types of media that are used in the drives.
 - 'Diskette change' signal: Copy protection might not be able to reset this signal.
- Write-current control: Copy protection that uses write-current control does not work, because the controller selects the proper write current for the media that is being used.

Detailed information about specific diskette drives is available in the *IBM Personal System/2 Hardware Interface Technical Reference—Common Interfaces* and in separate option technical references.

Hard Disk Drives and Controller

Reading from and writing to the hard disk is initiated in the same way as in IBM Personal Computer products; however, new functions are supported. Detailed information about specific hard disk drives and hard disk drive adapters is available in the *IBM Personal System/2 ATA/IDE Fixed Disk Drives Technical Reference*.

Software Compatibility

To maintain software compatibility, the interrupt polling mechanism that is used by IBM Personal Computer products is retained. Software that interfaces with the reset port for the IBM Personal Computer positive-edge interrupt sharing (hex address 02Fx or 06Fx, where x is the interrupt level) does not create interference.

Software Interrupts

With the advent of software interrupt sharing, software interrupt routines must daisy chain interrupts. Each routine must check the function value, and if it is not in the range of function calls for that routine, it must transfer control to the next routine in the chain. Because software interrupts are initially pointed to address 0:0 before daisy chaining, check for this case. If the next routine is pointed to address 0:0 and the function call is out of range, the appropriate action is to set the carry flag and do a RET 2 to indicate an error condition.

Machine-Sensitive Programs

Programs can select machine-specific features, but they must first identify the machine and model type. IBM has defined methods for uniquely determining the specific machine type. The machine model byte can be found through Interrupt 15H, Return System Configuration Parameters function ((AH)=C0H). See the *IBM Personal System/2 and Personal Computer BIOS Interface Technical Reference* for a listing of model bytes for other IBM Personal Computer products.

BIOS Compatibility

The personal computer systems support BIOS interfaces as described in the *IBM Personal System/2 and Personal Computer BIOS Interface Technical Reference*.

Chapter 6. Bus Architecture

- Bus Architecture Descriptions 46
 - ISA Bus 46
 - PCI Bus 47
 - PCI Performance 47
 - PCI Peripheral Devices 47
- Expansion-Bus Features 47
- Bus Voltage Levels 49

Bus Architecture Descriptions

This section gives an overview of input/output (I/O) buses and explains how advanced I/O buses can improve performance.

A computer *bus* is a pathway of wires and signals that carry (or transfer) information inside the computer. *Information* includes data, addresses, instructions, and controls. The microprocessor has an external bus, called the *microprocessor bus* or *local bus*, that carries information between the microprocessor and main memory. The local bus has the same bus width (64 bits) as the microprocessor and operates at the same external speed.

Another computer bus, the *I/O bus* or *expansion bus*, carries information between the microprocessor or memory and the I/O (peripheral) devices. While microprocessor-bus performance has improved rapidly, improvements in I/O-bus performance have not equalled those of microprocessors and some peripheral devices, such as video and disk controllers. Regardless of how fast the microprocessor and other components are, data transfers between them must pass through the I/O bus.

The computer has two I/O buses: the *ISA bus* and the *PCI bus*. ISA is the standard I/O bus used in IBM and IBM-compatible computers for many years. PCI is one of the advanced I/O bus standards developed by the computer industry to keep up with performance improvements of microprocessor buses and advanced peripheral devices. Although advanced designs can match the performance of the microprocessor bus only up to a point, they do achieve higher throughput by speeding up the I/O bus and widening its data path. PCI is intended to add to, but not replace, the capability provided by the ISA bus. In fact, most personal computers today need only three PCI connections: one for video, one for the disk controller, and one for a network adapter or other optional device.

ISA Bus

One of the most widely used and successful bus architectures is the AT bus, also called the *industry standard architecture (ISA) bus*, or the I/O channel. The ISA bus is a 16-bit bus that operates at a speed of 8 MHz. It can transfer up to 8 MB of data per second between the microprocessor and an I/O device. Practical performance ranges between 4 MB to 8 MB per second.

The ISA bus continues to be popular because so many adapters, devices, and applications have been designed and marketed for it. ISA is adequate for users of DOS applications in a stand-alone environment, or for DOS network requestors with moderate performance requirements.

Although the ISA bus is widely used and is suitable for many applications, it cannot transfer data fast enough for today's high-speed microprocessors and I/O devices. For example, the ISA bus might not provide for the performance needs of video devices and applications with high resolution and high-color content. Also, ISA might not be capable of handling the throughput required by some fast hard disks, network controllers, or full-motion video adapters.

The ISA bus is buffered to provide sufficient power for the 98-pin connectors, assuming two low-power Schottky (LS) loads per slot. The signal assignments and pin assignments for the I/O channel connectors are shown in Figure 18 on page 25.

PCI Bus

The PCI bus connects to the microprocessor local bus through a buffered bridge controller. A *bridge* translates signals from one bus architecture to another. PCI and ISA devices receive all their data and control information through the PCI controller. The PCI controller looks at all signals from the microprocessor local bus and then passes them to the ISA controller, or to peripheral devices connected to the PCI bus. However, the PCI bus is not governed by the speed of the microprocessor bus. PCI can operate at speeds as fast as 33 MHz, slow down, or even stop if there is no activity on the bus, all independent of the microprocessor's operations. This independence is a distinguishing feature of PCI that allows the microprocessor to do other work while the I/O bus is busy. Microprocessor independence also makes PCI adaptable to various microprocessor speeds and families and allows consistency in the design and use of PCI peripheral devices across multiple computer families.

PCI Performance

One of the most significant features of PCI is its 32-bit data path, which is twice the width of the ISA data path. With a 32-bit data path, the PCI bus can transfer more information per second than the ISA bus with its 16-bit data path. Also, PCI operates at higher speeds of up to 33 MHz. Depending on the mode of operation and computer components used, the PCI bus can transfer data at speeds up to 132 MB per second. While many factors can reduce practical performance, achieving just half or a third of the PCI maximum theoretical throughput far exceeds the practical performance of the ISA bus at 4 MB to 8 MB per second.

PCI Peripheral Devices

The wider data path and higher throughput make PCI a more suitable bus for today's high-speed microprocessors and I/O devices. Higher throughput translates into higher performance of peripheral devices, such as higher video resolutions, more colors, and quicker screen refreshes. The use of PCI architecture enhances the performance of the monitor and the storage devices. Both the video controller and the IDE drive controller are connected to the PCI bus on the system board. Thus, the peripheral devices that have the greatest demand for higher performance are supported by the benefits of PCI architecture.

Expansion-Bus Features

The bit-width of the I/O bus determines the type of adapters the computer supports. The shared slots handle 16-bit ISA adapters and 32-bit PCI adapters. The dedicated ISA slots handle 16-bit ISA adapters only. The width of the I/O bus does not affect software compatibility.

The PC 730 riser card has three shared PCI and ISA slots; the PC 750 riser card has three shared PCI and ISA slots and two dedicated ISA slots.

You can have up to three adapters in the PC 730 and up to five adapters in the PC 750. Each PCI connector and the ISA connector directly below it share an expansion-slot opening at the back of the computer that can be used by only one adapter at a time. This means that you can install either a PCI adapter or an ISA adapter in a shared slot, but not both.

Chapter 6. Bus Architecture

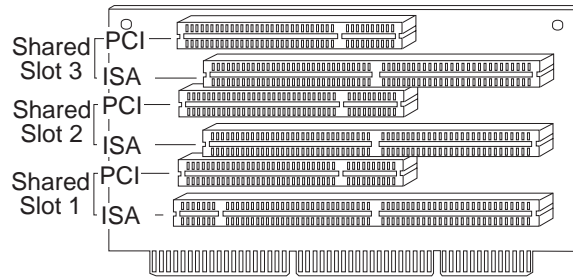

ISA/PCI Riser Card for PC 730

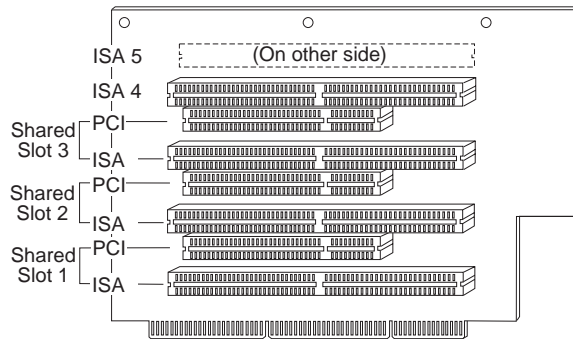

ISA/PCI Riser Card for PC 750

PCI connectors support both 3.52-volt and 5-volt adapters. A separate power cable connects to the back of the riser card to supply 3.52-volt power.

PCI devices receive data through the PCI controller. The PCI controller looks at all signals from the microprocessor local bus, then passes them to the ISA controller or to peripherals connected to the PCI bus.

The signal assignments and pin assignments for the PCI connectors are shown in Figure 19 on page 26. For additional information, see the *PCI Local Bus Specification*, published by the PCI Special Interest Group.

Bus Voltage Levels

Four voltage levels are provided for I/O adapters. The maximum available values (for each slot) are as follows:

- +5 V dc (+5%, -4.5%) at 2.0 A
- -5 V dc (+10%, -9.5%) at 0.100 A
- +12 V dc (+5%, -4.5%) at 0.175 A
- -12 V dc (+10%, -9.5%) at 0.100 A

The I/O CH RDY signal is available on the I/O channel to allow operation with slow I/O or memory devices. I/O CH RDY is held inactive by an addressed device to lengthen the operation. For each clock cycle that the line is held inactive, one wait state is added to the I/O or DMA operation.

Two voltage levels are provided for PCI bus adapters. The maximum available values (for each slot) are as follows:

- +5 V dc (+5%, -4.5%) at 7.576 A
- +3.52 V dc (+2.5%, -2.5%) at 4.00 A

Appendix A. Error Codes

The following figures list the POST error codes and beep error codes for the computer.

POST Error Codes

POST error messages appear when POST finds problems with the hardware during power-on or when a change in the hardware configuration is found. POST error messages are 3-, 4-, 5-, 8-, or 12-character alphanumeric messages. An x in an error message can represent any number.

Figure 36 (Page 1 of 2). POST Error Messages

Code	Description
101	Interrupt failure
102	Timer failure
103	Timer-interrupt failure
104	protected mode failure
105	last 8042 command not accepted –keyboard failure
106	System board failure
108	Timer bus failure
109	low MB chip select test
110	System board parity error 1 (system board parity latch set)
111	I/O parity error 2 (I/O channel check latch set)
112	I/O channel check error
113	I/O channel check error
114	external ROM checksum error
115	DMA error
116	System board port read/write error
120	Microprocessor test error
121	Hardware error
151	Real time clock failure
161	Bad CMOS Battery
162	CMOS RAM checksum/configuration error
163	Clock not updating
164	CMOS RAM memory size does not match
167	Clock not updating
175	Riser card or system board error
176	System cover has been removed
177	Corrupted administrator password
178	Riser card or system board error
183	Administrator password has been set and must be entered
184	Password removed due to checksum error
185	Corrupted boot sequence
186	System board or hardware security error
189	More than three password attempts were made to access system
201	Memory date error
202	Memory address line error 00-15
203	Memory address line error 16-23
221	ROM to RAM remapping error
225	Unsupported memory type installed or memory pair mismatch
301	Keyboard error
302	Keyboard error
303	Keyboard to system board interface error
304	Keyboard clock high
305	No keyboard +5 V
601	Diskette drive or controller error
602	Diskette IPL boot record not valid
604	Unsupported diskette drive installed
605	POST cannot unlock diskette drive
662	Diskette drive configuration error
762	Math coprocessor configuration error

Figure 36 (Page 2 of 2). POST Error Messages

Code	Description
11xx	Serial port error (xx = serial port number)
1762	Hard disk configuration error
1780	Hard disk 0 failed
1781	Hard disk 1 failed
1782	Hard disk 2 failed
1783	Hard disk 3 failed
1800	PCI adapter has requested an unavailable hardware interrupt
1801	PCI adapter has requested an unavailable memory resource
1802	PCI adapter has requested an unavailable I/O address space, or a defective adapter
1803	PCI adapter has requested an unavailable memory address space, or a defective adapter
1804	PCI adapter has requested unavailable memory addresses
1805	PCI adapter ROM error
1962	Boot sequence error
2401	System board video error
8601	System board - keyboard/pointing device error
8602	Pointing device error
8603	Pointing device or system board error
12092	Level 1 cache error (Processor chip)
12094	Level 2 cache error
16101	Riser card battery is dead
I9990301	Hard disk failure
I9990305	No operating system found

Beep Codes

For the following beep codes, the numbers indicate the sequence and number of beeps. For example, a “2-3-2” error symptom (a burst of two beeps, three beeps, then a burst of two beeps) indicates a memory module problem. An x in an error message can represent any number.

Figure 37. Beep Codes

Beep Code	Probable Cause
1-1-3	CMOS write/read failure
1-1-4	BIOS ROM checksum failure
1-2-1	Programmable interval timer test failure
1-2-2	DMA initialization failure
1-2-3	DAM page register write/read test failure
1-2-4	RAM refresh verification failure
1-3-1	1st 64 K RAM test failure
1-3-2	1st 64 K RAM parity test failure
2-1-1	Slave DMA register test in progress or failure
2-1-2	Master DMA register test in progress or failure
2-1-3	Master interrupt mask register test failure
2-1-4	Slave interrupt mask register test failure
2-2-2	Keyboard controller test failure
2-3-2	Screen memory test in progress or failure
2-3-3	Screen retrace tests in progress or failure
3-1-1	Timer tick interrupt test failure
3-1-2	Interval timer channel 2 test failure
3-1-4	Time-of-Day clock test failure
3-2-4	Comparing CMOS memory size against actual
3-3-1	Memory size mismatch occurred

Appendix B. Notices and Trademarks

References in this publication to IBM products, programs, or services do not imply that IBM intends to make these available in all countries in which IBM operates. Any reference to an IBM product, program, or service is not intended to state or imply that only that IBM product, program, or service may be used. Subject to IBM's valid intellectual property or other legally protectable rights, any functionally equivalent product, program, or service may be used instead of the IBM product, program, or service. The evaluation and verification of operation in conjunction with other products, except those expressly designated by IBM, are the responsibility of the user.

IBM may have patents or pending patent applications covering subject matter in this document. The furnishing of this document does not give you any license to these patents. You can send license inquiries, in writing, to:

IBM Director of Licensing
IBM Corporation
500 Columbus Avenue
Thornwood, NY 10594
U.S.A.

Trademarks

The following terms are trademarks of the IBM Corporation in the United States or other countries or both:

AT	Personal Computer AT
IBM	Mwave
Personal System/2	PS/2

The following terms are trademarks of other companies:

Hercules	Hercules Computer Technology
Intel	Intel Corporation
Matrox	Matrox Electronic Systems, Ltd.
Motorola	Motorola, Incorporated
National Semiconductor	National Semiconductor Corporation
PCMCIA	Personal Computer Memory Card International Association
Pentium	Intel Corporation
S3	S3 Incorporated
Sound Blaster	Creative Technology Ltd.
VESA	Video Electronics Standards Association

Microsoft, Windows, and Windows NT, are trademarks or registered trademarks of Microsoft Corporation.

Index

Numerics

16550-UART 32

A

adapters, adding 47
address map
 DMA 10
 system memory 7
advanced power management 18
altitude 16, 17
answering machine 33
APM 18
AT bus 46
AT-compatible mode (parallel port) 35
audio subsystem 4

B

baud rate 32
beep codes 51
bidirectional mode (parallel port) 35
BIOS data areas 7
bus
 AT 46
 ISA 46
 PCI 47
bus architecture 4
bypassing BIOS 43

C

cables 16, 17
cache memory 39
CMOS RAM 4
compatibility
 hardware 41
component maximum current 14
connector
 diskette drive 23
 display 36
 hard disk drive 24
 infrared 30
 ISA bus 25
 memory 28
 mouse 31
 parallel port 34
 PCI (peripheral component interconnect) 26
 PCMCIA 21
 power supply 27
 serial port controller 32

controller
 diskette drive 5, 42
 keyboard/auxiliary-device 5
 parallel 5
 serial 5
copy protection 43
current, electrical 16, 17

D

data collaboration 33
depth, system unit 16, 17
description
 AT bus 46
 diskette drive connector 23
 display connector 36
 hard disk drive connector 24
 I/O channel 46
 ISA bus 46
 keyboard and auxiliary-device controller
 connector 31
 parallel port connector 34
 PCI (peripheral component interconnect)
 connector 26
 PCI connector 26
 power supply 12
 power supply connectors 27
 system board memory connector 28
direct memory access (DMA) channel assignments 11
diskette drive
 change signal 43
 compatibility 43
 connector 23
 controller 5
 signals 23
 write current 43
diskette drives 42
display connector signal and pin assignments 36
DMA
 I/O address map 10
DMA (direct memory access) channel assignments 11

E

ECP (extended capabilities port) 35
ECP/EPP 35
edge-triggered interrupts 41
electromagnetic compatibility 16, 17
enhanced parallel port (EPP) 35
environment, operating 16
EPP (enhanced parallel port) 35

error codes, POST 50
 expansion bus 46
 extended capabilities port (ECP) 35

F

fault, overvoltage 15
 fax 33
 features 2
 flash ROM 4
 frequency 16, 17
 frequency, input power 12

H

hard disk drive
 compatibility 43
 connector 24
 controller 43
 signals 24
 hard disk drive connector signal and pin assignments 24
 hardware compatibility 41
 hardware interrupts 41
 heat output 16, 17
 height, system unit 16, 17
 humidity 16, 17

I

I/O
 features 29
 I/O address map
 DMA 10
 I/O channel (ISA) description 46
 infrared (IR) connector 30
 input power
 frequency 12
 requirements 12
 voltage 12
 interrupt request assignments 11
 ISA bus connector signal and pin assignments 25

J

jumper
 locations (system board) 6

K

keyboard and auxiliary-device controller connector 31
 keyboard and auxiliary-device signal and pin assignments 31
 keyboard cable 16, 17
 keyboard signal and pin assignments 31

L

L1 cache 39
 L2 cache 39
 level-sensitive interrupts 41
 load currents 14
 local bus 46

M

machine-sensitive programs 44
 Matrox Millennium adapter 20
 measurements, system unit 16, 17
 memory
 cache 39
 connector 28
 error in 7
 L1 cache 39
 L2 cache 39
 map, system 7
 RAM 7, 38
 system memory map 7
 messages, POST error 50
 microprocessor
 features 4
 microprocessor upgrade socket 4
 modem 33
 modes, power management 18

O

outputs, power supply 14
 overview 2
 overvoltage fault 15

P

parallel port 5
 parallel port connector 34
 parallel port connector signal and pin assignments 34
 password
 PC Cards 21
 PCI connector signal and pin assignments 26
 Pentium microprocessor 4
 physical specifications
 PC 350 17
 polling mechanism 43
 port
 parallel 5
 serial 5
 POST 7
 POST error codes 50
 power
 cable 16, 17
 consumption 18
 description 12
 for components 14

Index

power (*continued*)
 load currents 14
 management modes 18
 output protection 15
 outputs 14
 specifications 16, 17
power supply connectors 27
protection, power supply 15
PS/2-compatible mode (parallel port) 35
publications, related vi

R

RAM (random access memory) 4, 7, 38
random access memory (RAM) 4, 7, 38
related publications vi
reserved
 areas vi
riser card 47
RT/CMOS RAM
 error in 7

S

SCSI (small computer system interface) 21
serial port 5
serial ports 32
short circuit 15
signals
 diskette drive 23
 hard disk drive 24
SIMMs (single inline memory modules) 38
single inline memory modules (SIMMs) 38
size, system unit 16, 17
small computer system interface (SCSI) 21
socket, microprocessor upgrade 4
software
 compatibility 43
 interrupts 43
speaker phone 33
specifications
 physical 16
standard mode (parallel port) 35
system
 description 2
 memory maps 7
 specifications 16
 timers 4
system board
 devices 4
 diskette drive connector 23
 display connector 36
 features 4, 6
 hard disk drive connector 24
 keyboard and auxiliary-device controller
 connector 31

system board (*continued*)
 memory connector 28
 parallel port connector 34
 PCI (peripheral component interconnect)
 connector 26
 power supply connectors 27
 video feature connector 29

T

temperature 16, 17
timers, system 4

U

UART (universal asynchronous receiver/transmitter) 32
unidirectional mode (parallel port) 35
universal asynchronous receiver/transmitter (UART) 32

V

video
 feature connector 29
 local-bus 4
 Matrox Millennium adapter 20
 subsystem 4
voltage, input power 12

W

warning, reserved areas vi
wave (.WAV) files, playing 33
weight, system unit 16, 17
width, system unit 16, 17
write current, diskette 43



Part Number: 52H3381

Printed in U.S.A.

